



SV380 & SV500

Manual Stop Valve for
High-Pressure Gases
(DN15)



YOUR CREATIVE ENGINEERING PARTNER

SV380 & SV500

Manual Stop Valve for High-Pressure Gases

Series SV380 and SV500 are Manual Stop Valves, developed for use in high-pressure gas applications where reliability, long service life and leak integrity are critical.

Connection is via flanged adaptors which either have industry standard threaded ports or weld stub connections suitable for brazing or welding to pipework. Hale Hamilton can provide connection adaptors to meet individual requirements on request.

HIGHLIGHTS

- > Conforms to Pressure Equipment Directive 97/23/EC (PED)
- > TPED (EN ISO 10297:2014 +A1,2017) approved
- > Exceptional leak integrity
- > Available with a range of port connections via addition of zero clearance flanges

IDEAL USES

- > Primary Isolation of Mobile or Static Storage
- > Vessels (Hydrogen, CNG & Biomethane)
- > Gas Control Panels
- > High Pressure Test Rigs



Hydrogen

Maximum Working Pressure
380 & 500
barg (5510 psig) barg (7250 psig)

TPED
Approved

FEATURES AND SPECIFICATIONS

Handwheel

- > Low operating torque at all pressures

Bi-Directional Valves

- > Bi-directional valve ensures flow in both directions

Flanges/Adaptors

- > Different Flange adaptors/ threaded ports/weld stubs available



PRODUCT SPECIFICATION DATA	SV 380	SV 500
DN Size	DN15	DN15
Orifice Size	11mm	
Inlet Rating	380 barg (5510 psig)	500 barg (7250 psig)
Medium	Industrial Gases Including Hydrogen	
Design Pressure	475 barg (6,890psig)	600 barg (8,700psig)
Temperature Range	-40°C – +65°C	
Weight	6.8 kg	
Leakage	Bubble Tight	
Cv	4.5	
Valve Body Material	Stainless Steel 316L	
Handwheel Material	Nickel Aluminium Bronze	
Seals Material	PEEK, HNBR, PTFE, Nitrile	

PRODUCT DIMENSIONS (IN MM)

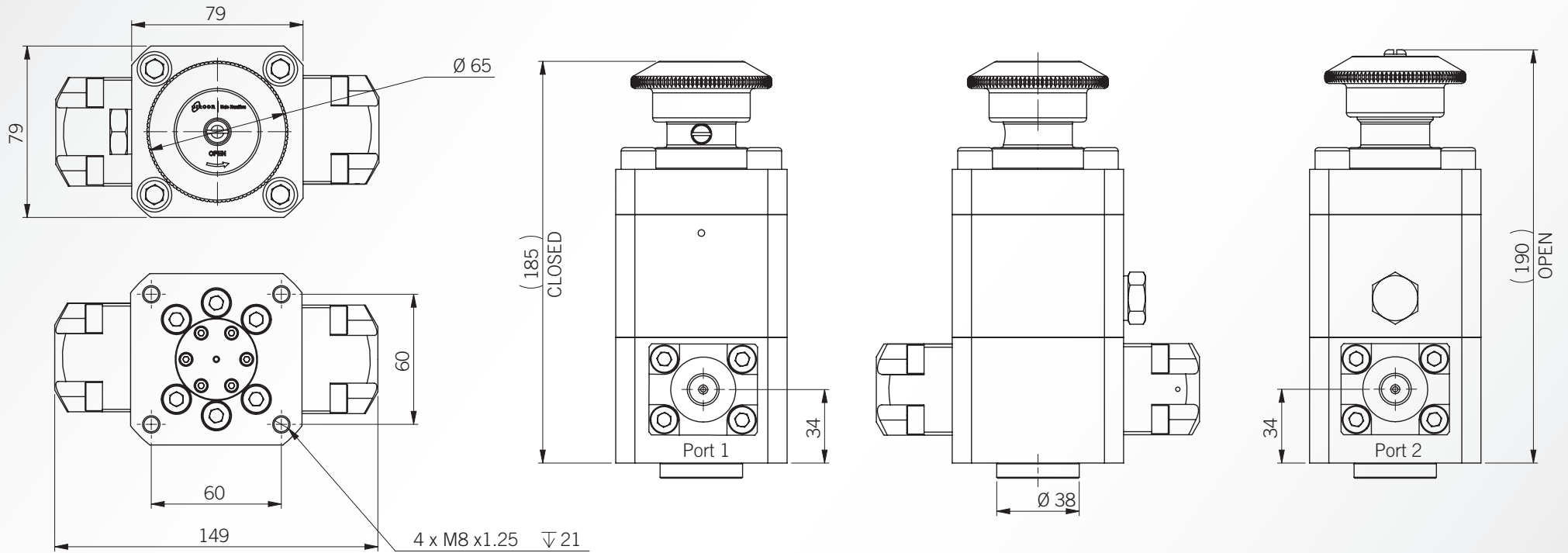

OPERATING CODES & ORDERING INFORMATION

Valve Type	Series	INLET FLANGE		OUTLET FLANGE*		CLEANING	SPECIAL FEATURE
SV	380	A	1/2" NPT - Female Stainless Steel	A	1/2" NPT - Female Stainless Steel	C2 - Commercial Clean	Omit if None
	500	C	3/4" NPT - Female Stainless Steel	C	3/4" NPT - Female Stainless Steel	C49 High Purity Clean	
		D	G 1/2" Female Stainless Steel	D	G 1/2" Female Stainless Steel		
		E	G 3/4" Female Stainless Steel	E	G 3/4" Female Stainless Steel		
		F	3/4" Medium Pressure Female Stainless Steel	F	3/4" Medium Pressure Female Stainless Steel		
		G	1/4" High Pressure Female Stainless Steel	G	1/4" High Pressure Female Stainless Steel		
		H	1" XXS BUTT WELD, Stainless Steel	H	1" XXS BUTT WELD, Stainless Steel		
		J	3/4" XXS BUTT WELD, Stainless Steel	J	3/4" XXS BUTT WELD, Stainless Steel		
		K	9/16" MP (13/16UN) Female Stainless Steel	K	9/16" MP (13/16UN) Female Stainless Steel		

*Only used if outlet flange different to inlet.

PRODUCT ORDERING INFORMATION

While placing the enquiry please advise the following

- > Ordering Code
- > Gas Type