



INSTRUCTION MANUAL

SERIES 3R

WARNING

**READ CA-1 AND THIS INSTRUCTION BOOK BEFORE
INSTALLATION, OPERATION, OR MAINTENANCE**

This manual now is
identified as part no.
SRM00023

FOREWORD

This instruction manual covers the Imo Pump Series 3R IMO pumps, rotor sizes 437, 462, 550 and 630. Specific models covered by this manual are identified in Table 1. The model of each particular pump is identified on the pump nameplate. Refer to Figure 1 for definitions of model designators. Refer to assembly drawing, Figure 4, and mechanical seal drawings, Figures 2 and 3, as you use this instruction manual.

**TABLE 1
3R SERIES IMO PUMP MODELS**

Rotor Sizes 437 thru 630 (1)	
Pump Model	Seal Fig. No.
3RBF	2
3RBFS	2
3RYTF	3
3RYTFS	3
(1) Pump Model precedes Rotor Size	

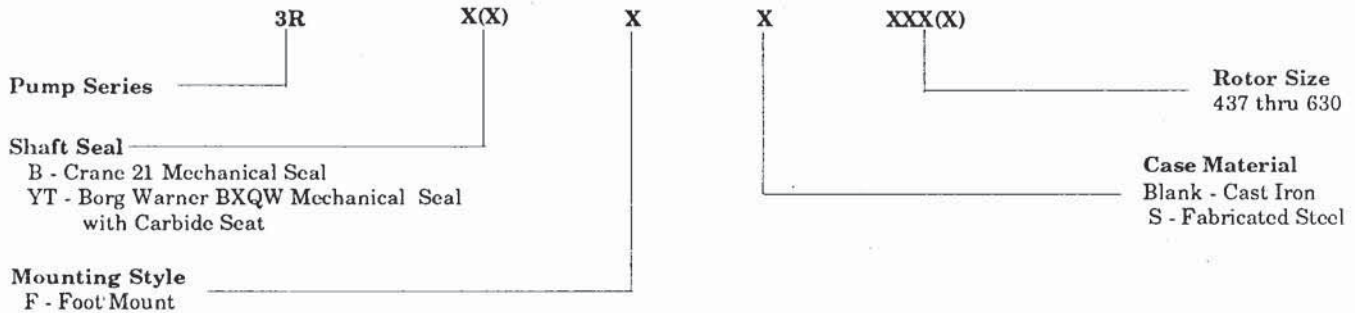

FIGURE 1. Definitions of Model Designators

STRUCTURAL LIMITS

Operating conditions such as speed, fluid viscosity, inlet pressure, discharge pressure, temperature, filtration, duty cycle, mounting, drive type, etc. are interrelated. Due to these variable conditions, the specific application may be different from that of the structural limitations. This equipment must not be operated without verification that operating requirements are within published capabilities as shown in the appropriate pump data book (available from local Imo Pump offices and representatives listed in Manual CA-1). *Under no circumstances are the following structural limitations to be exceeded.*

Maximum Speed:	Rotor Size	437P,462,462J,462M,550J,550M,630J	550, 630M	630
	Speed	1800	1500	1200

Viscosity: 2.0 cst (33 SSU) Minimum
 3000 SSU Maximum – Type B Mechanical Seal (Consider Cold Start Conditions.)
 50,000 SSU Maximum – Type YT Mechanical Seal (Consult factory with applications over 50,000)

Temperature: 0° to 180° – Type B Mechanical Seal
 0° to 375° – Type YT Mechanical Seal

Suction: 30 PSIG Maximum

Discharge Pressure: 300 PSIG (Maximum)

Drive: Direct Only

Filtration: Light fluids – 60 mesh
 Heavy fluids – 1/16 to 1/8-inch

MAINTENANCE

Maintenance procedures in this manual are divided into Replacement of Internal Cartridge, Servicing Ball Bearing and/or Mechanical Seal and Pump Disassembly and Reassembly Procedures. Read and establish a complete understanding of the applicable procedure prior to performing maintenance.

WARNING

Prior to any maintenance procedure, (1) Remove electrical service fuse and lock deenergized the electrical service panel supply to driver and (2) Shut, wire or chain shut and lock all pump piping valves.

Depending on type of coupling installed (clearance between pump and driver shaft ends), maintenance of ball bearing and mechanical seal can be performed without removal of pump driver. In instances involving restricted space and where removal of driver is not possible, follow procedures outlined in Disassembly and Reassembly of pump to service mechanical seal and/or ball bearing. If replacement of internal cartridge or complete overhaul of pump is required, necessary steps must be taken to permit space for removal of cartridge from suction end of pump. Due to weight of internal cartridge, outlined in Replacement of Internal Cartridge, necessary supporting devices must be provided prior to removal of cartridge.

REPLACEMENT OF INTERNAL CARTRIDGE

1. With pump driver deenergized and all valving locked shut, remove plug (039) and drain pump. Remove checknut (033) and pump coupling hub. Disconnect system piping from suction end of pump.

NOTE

Space must be provided at suction end of pump for removal of cartridge.

2. Remove nuts (007) and bolts (006) and remove inlet head (001) from outlet cover (003). Remove gasket (008) from either inlet head (001) or outlet cover (003) flange.

WARNING

When removing internal cartridge, provisions must be made for collection of fluid entrapped in discharge end of pump.

3. Due to weight of the cartridge, outlined in Table 2, support the suction end of the internal cartridge with a sling and hoist the cartridge from the outlet cover (003). As the cartridge emerges from cover (003), a sling should be attached approximately mid-point of the cartridge to aid in support of the weight.

TABLE 2
APPROXIMATE WEIGHTS OF INTERNAL CARTRIDGE

Rotor Size	437, 462	550	630
Weight (Lbs.)	600	800	1000

NOTE

Removal of internal cartridge will remove all remaining pump parts from outlet cover (003).

4. To install internal cartridge, support cartridge with sling(s), based on above weights, and hoist cartridge into outlet cover (003), ensuring that rotor housing (009) is centered and properly positioned. Care should be taken to avoid damage to O-ring (014) during installation of cartridge. Install gasket (008) on flange of outlet cover (003). Install inlet head (001) on outlet cover (003) using bolts (006) and nuts (007). Torque nuts (007) to 200 lbs. ft. (± 5 lbs. ft.). Install plug (039) in inlet head (001). Install pump coupling hub and verify alignment. Remove locks and wiring from pump valving. Fill pump with fluid, expelling all air. Rotate power rotor to flood chamber area between housing and rotors. Remove lock from electrical service; install fuse; and with system piping and valving correctly positioned, start pump as needed.

SERVICING BALL BEARING AND/OR MECHANICAL SEAL

1. With pump driver deenergized and all valving locked shut, disconnect coupling. Remove checknut (033). Remove pump coupling hub and key (029) from power rotor (020).
2. Remove bolts (032) and retainer (031) from Balance Piston Housing (013). If applicable to pump type assembly, lip seal (040) will be removed with retainer (031). Remove lip seal (040) from retainer (031).
3. Remove assembled power rotor (020) from pump. Removal of power rotor (020) includes removal of retaining rings (028), bearing (027), lip seal (041) (if applicable to pump type assembly), spacer subassembly (023), O-ring (026), and mechanical seal (034).
4. Disassemble power rotor (020) as follows:
 - a. Remove outer retaining ring (028) from groove of power rotor (020) shaft. Using a bearing puller, remove bearing (027) from power rotor (020) shaft.

NOTE

If replacement of mechanical seal (034) is NOT necessary, proceed to Step 9. If replacement of mechanical seal (034) IS necessary, proceed as follows:

- b. Remove inner retaining ring (028). Remove spacer sub-assembly (023) from power rotor (020) shaft. Removal of spacer sub-assembly (023) will also remove O-ring (026), lip seal (041) and mechanical seal stationary seat and O-ring (1 and 2, Figure 2 or 3).
- c. Remove O-ring (026) from groove of spacer (023). Remove mechanical seal seat and O-ring (1 and 2, Figure 2 or 3) from spacer (023). Remove O-ring (2, Figure 2 or 3) from seal seat (1, Figure 2 or 3).

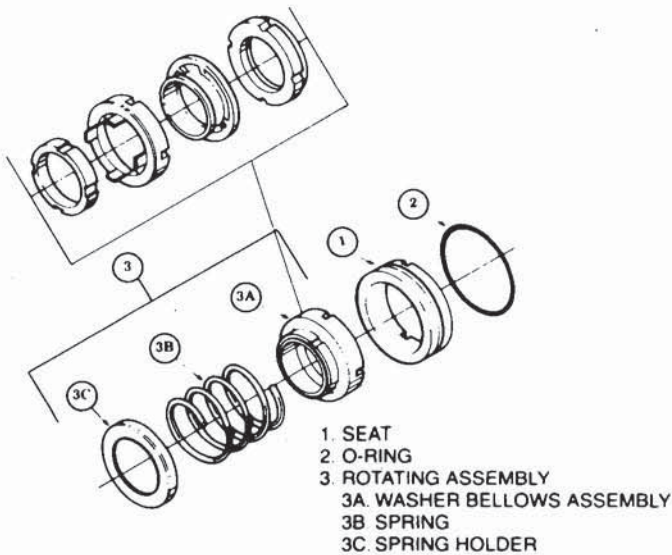

FIGURE 2. Crane 21 Mechanical Seal

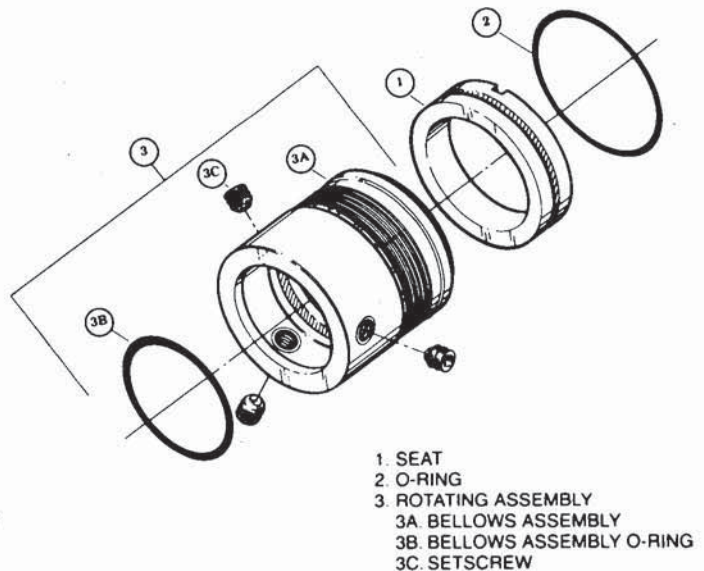

FIGURE 3. Borg-Warner BXQW Mechanical Seal

5. Remove mechanical seal (034) rotating assembly from power rotor (020) shaft as follows:

Crane Type 21 (Figure 2). Slide rotating assembly (3) from power rotor.

Borg-Warner Type BXQW (Figure 3). Loosen setscrews (3C) and slide rotating assembly (3) from power rotor.

NOTE

Prior to reassembly of power rotor (020), clean and inspect all parts. Use light lubricating oil, or wipe all parts immediately before assembly.

6. Install mechanical seal (034) rotating assembly as follows:

Crane Type 21 (Figure 2). Slide rotating assembly (3) on power rotor (020) shaft next to balance piston (021).

Borg Warner Type BXQW (Figure 3). Slide rotating assembly (3) on power rotor (020) shaft next to balance piston (021). Tighten setscrews (3C).

7. Assemble spacer (023) as follows:

- a. Install O-ring (2, Figure 2 or 3) on mechanical seal seat (1, Figure 2 or 3). Install assembled seal seat (1, Figure 2 or 3) in counterbore of spacer (023), ensuring that roll pin (025) engages bore in seal seat.
- b. If applicable to pump type assembly, install lip seal (041) in spacer (023) as indicated on assembly drawing, Figure 4.
- c. Install O-ring (026) in groove of spacer (023).

8. Install assembled spacer (023) on power rotor (020) shaft. Install inner retaining ring (028) in groove of power rotor (020) shaft. If applicable, fill recessed chamber of spacer (023) between lip seal (041) and retaining ring (028) with Mobil Grease No. 28 or equivalent to ensure proper lubrication of bearing.

NOTE

Pumps equipped with Crane Type 21 mechanical seal in rotor sizes 437P and 462 do not require grease packing. All other bearings are to be hand packed with grease.

9. Press bearing (027) on power rotor (020) shaft, pressing only on inner race of bearing. Install outer retaining ring (028) in groove of power rotor (020) shaft to retain bearing.
10. Install assembled power rotor (020) in pump by meshing threads of power rotor (020) with threads of idlers (022) and rotating power rotor in the normal direction of rotation.
11. If applicable to pump type assembly, install lip seal (040) in retainer (031) as indicated on assembly drawing, Figure 4. If applicable, pack recessed chamber of retainer (031) with Mobil Grease No. 28 or equivalent to ensure proper lubrication of bearing. Install retainer (031) to balance piston housing (013) by installing bolts (032). Torque bolts (032) to 15 lbs. ft. (± 2 lbs. ft.).

NOTE

With grease gun, repack ball bearing with Mobil Grease No. 28 or equivalent every 1000 hours.

13. Install key (029) in keyway of power rotor (020) and install pump coupling hub. Install checknut (033).
14. Remove locks from pump valving. Remove lock from electrical service; install fuse; and with system pipe valving correctly positioned, start pump as needed.

PUMP DISASSEMBLY AND REASSEMBLY PROCEDURES

Disassembly of Pump

1. Follow procedures outlined in Steps 1 through 3 of Replacement of Internal Cartridge. Locate cartridge in a clean, suitable work area. Disassemble internal cartridge as outlined below. Refer to pump assembly drawing, Figure 4; Mechanical seal drawings, Figures 2 and 3; and List of Material, Table 3, during disassembly procedures.
2. Remove key (029) from keyway of power rotor (020) shaft.
3. Remove bolts (012), spacers (011) and thrust plate (010) from rotor housing (009).
4. Remove idlers (022) from idler bores at suction end of rotor housing (009).
5. Remove and disassemble power rotor (020) by following procedures outlined in Steps 2 through 5 of Servicing Ball Bearing and/or Mechanical Seal.
6. Remove assembled balance piston housing (013) from rotor housing (009) by removing bolts (015). Disassemble balance piston housing as follows:
 - a. Remove O-ring (014) from groove of balance piston housing (013).
 - b. Remove bolts (017) and washers (016) and remove bushing (018) from balance piston housing (013).

Reassembly of Pump

NOTE: Prior to assembly of pump, all parts should be cleaned and inspected for nicks or burrs. Replace all worn or damaged parts. It is recommended that gasket (008), O-rings (014 and 026), mechanical seal (034), bearing (027), and lip seals (040 and 041) be replaced when disturbed from their original installed position. Wipe each part with light lubricating oil prior to installation. Refer to assembly drawing, Figure 4; mechanical seal drawings, Figures 2 and 3; and List of Material, Table 3, during reassembly of pump.

1. Install bushing (018) in balance piston housing (013). Install washers (016) and bolts (017) in balance piston housing (013) to retain bushing (018).
2. Install O-ring (026) in groove of balance piston housing (013). Install assembled balance piston housing (013) on rotor housing (009) using bolts (015). Torque bolts (015) to 51 lbs. ft. (± 2 lbs. ft.).
3. Install idlers (022) in idler bores of rotor housing (009).
4. Install thrust plate (010) on rotor housing (009) using spacers (011) and bolts (012). Torque bolts (012) to 51 lbs. ft. (± 2 lbs. ft.).
5. Follow procedures outlined in Steps 6 thru 13 of Servicing Ball Bearing and/or Mechanical Seal to assemble and install power rotor (020).
6. Follow procedures outlined in Step 4 of Replacement of Internal Cartridge to complete reassembly of pump.

**TABLE 3
LIST OF MATERIAL**

Item	Part Description	Item	Part Description
001	Inlet Head	023	Spacer Sub-assembly
003	Outlet Cover	024	Spacer (Part of Item 023)
006 (3)	Bolt (12)	025	Roll Pin (Part of Item 023)
007 (3)	Nut (12)	026 (1)	O-ring
008 (1)	Gasket	027 (1)	Bearing
009 (2)	Rotor Housing	028 (1)	Retaining Ring (2)
010 (2)	Thrust Plate	029	Key
011 (2)	Spacer (4)	030	Pipe Plug
012	Bolt (4)	031	Retainer
013	Balance Piston Housing	032	Bolt (4)
014 (1)	O-ring	033	Checknut
015 (2)	Bolt (3)	034 (1)	Seal
016 (2)	Washer (3)	035	Nameplate
017 (2)	Bolt (3)	036	Drive Screw (3)
018 (2)	Balance Piston Bushing	039	Pipe Plug
019 (2)	Power Rotor Sub-assembly	040 (1)	Lip Seal
020 (2)	Power Rotor (Part of Item 019)	041 (1)	Lip Seal
021 (2)	Balance Piston (Part of Item 019)	042 (2)	Grease Fitting
022 (2)	Idler (2)		

Quantities are one (1) except when noted in parentheses after part description.

- (1) Minor Repair Kit Items.
- (2) Major Repair Kit items. Items marked (1) also included in Major Repair Kit.
- (3) Quantity is sixteen (16) for rotor size 630 pumps.

NOTE:

Lip seals (040 and 041) are not applicable to pumps equipped with Crane Type 21 Mechanical Seals in rotor size 437P only.

ORDERING INSTRUCTIONS

- (1) Give the number of the instruction book.
- (2) Give the model number and serial number of pump for which kit is required.
- (3) Identify the kit (Minor or Major) required.

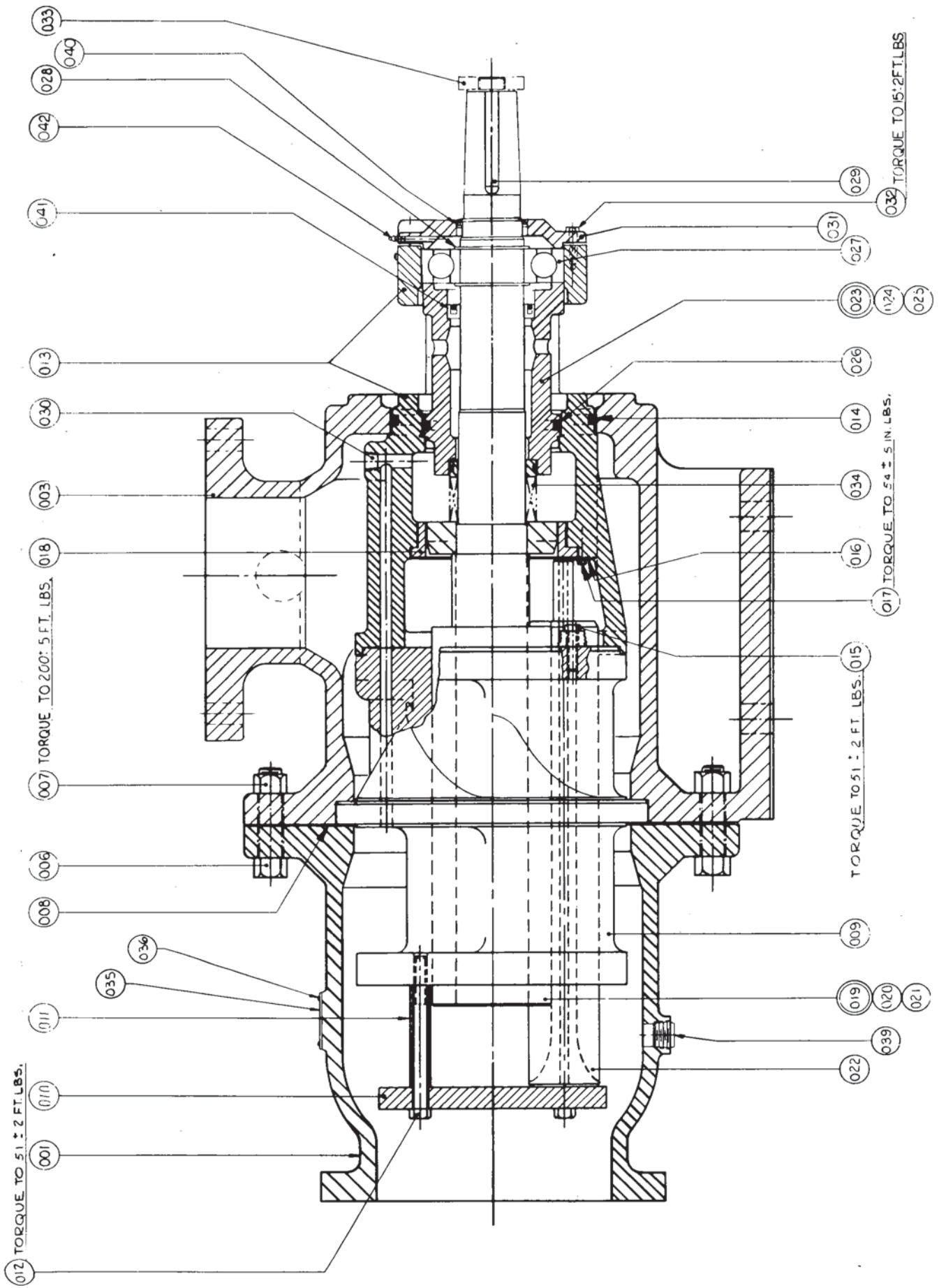
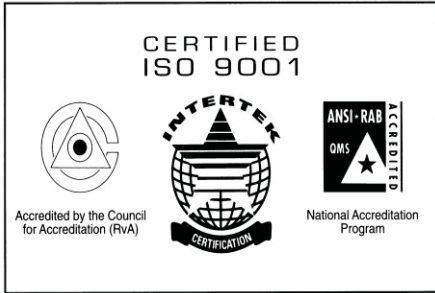

FIGURE 4. Pump Assembly



CIRCOR

1710 Airport Road
PO Box 5020
Monroe, NC USA
28111.5020

Tel: +1. 877.853.7867

Email: cc@circor.com

Web: www.circorpt.com

