



**INSTRUCTIONS and PARTS LIST**

# **SERIES 6UVX-187R**

**WARNING**

**READ THIS INSTRUCTION BOOK AND CA-1 BEFORE  
INSTALLATION, OPERATION OR MAINTENANCE**

**Instructions 6UVX-(R-4)**

This manual now is  
identified as part no.  
SRM00030

## **FOREWORD**

This manual covers the 6UVX-187R series IMO pump. The pump model is indicated on the nameplate (031) found on the pump. It is primarily used as a shaft mounted fuel injection pump for gas turbines. This design's construction utilizes Viton "O" Rings and a John Crane Type 21 Viton Bellows mechanical seal with a Buna lip seal as a back-up.

## **OPERATIONAL SAFETY PRECAUTIONS**

### **Structural Limits**

Operating conditions, such as speed, fluid viscosity, inlet pressure, discharge pressure, temperature, filtration, duty cycle, mounting, drive type, etc. are interrelated. Due to these variable conditions, the specific application limitation may be differed from that of the structural limitations. This equipment must not be operated without verification that operating requirements are within published capabilities as shown in the appropriate pump data book (available from local IMO Pump Division offices and representatives).

Under no circumstances are the following structural limitations to be exceeded.

**Maximum Discharge Pressure — 1000 PSIG**

(NOTE: Under controlled conditions with factory approval)

**Maximum Inlet Pressure — PSIG:50 (discharge pressure must always be 25 PSI above suction pressure).**

**Maximum Fluid Temperature — 200°F**

## **MAINTENANCE**

When the pump is installed properly, it should operate satisfactorily with very little attention other than periodic check of the suction strainer, bearing (020), mechanical seal (018) and oil seal (092). A seal leak detection line is provided at the inboard end of pump and through the mounting flange.

When a loss of flow or pressure is indicated, an inspection of all components should be made after first checking that the problem is not due to system malfunction as previously explained.

## ASSEMBLY AND DISASSEMBLY PROCEDURES

### Disassembly of Pump

**Step 1** – Close off suction and discharge piping to pump. Disconnect piping and uncouple pump from its driver. Drain pump case by allowing oil to spill from the outlet. Rotate rotors to drain oil trapped in rotors. Remove pump and place on a bench or suitable support.

**Step 2** – Remove taper pull pins (093) by tightening nuts (094). Remove nuts (004), capscrews (003), inlet head (002) and gasket (006) together with assembled parts as follows: Outboard end cover (045), seal housing (087), dowel pins (088), lip seals (086), retainer (096), capscrews (091) and (095) and gaskets (046).

**Step 3** – Remove setscrews (085) and use a puller to remove coupling (084) from end of power rotor (010). Remove "O" ring (097). Remove lip seals (086) and retainer (096). The coupling, lip seals and retainer will normally not be required and may be discarded. In the event it is necessary to connect a sine-wave generator to the pump again, it is recommended they be replaced.

**Step 4** – Remove capscrews (027), thrust plate (028) and spacers (041) (spacers are a matched set and should remain together for reassembly as a pair). Screw out idler rotors (011).

**Step 5** – Remove capscrews (009), bearing retainer (008) and oil seal (092). Pull power rotor assembly out of inboard end. The power rotor assembly consists of the power rotor (010), ball bearing (020), bearing spacer (019), mechanical seal (018) and retaining rings (021).

**Step 6** – Refer to page 4 for disassembly of power rotor assembly.

**Step 7** – An inspection of the housing bores and the rotors may now be made. When it is necessary to remove the rotor housing (015), remove capscrews (017) and housing (015). The two piece clamp ring (036), spring pin (042), back-up ring (035) and "O" ring (016) will be removed with the housing. The floating bushing (007), spacer (043), idler stop plate (014) and capscrews (044) may remain assembled in outlet cover (083) unless replacement is necessary.

### Reassembly

Inspect and clean parts before reassembly. New gaskets, mechanical seal (018), oil seal (092) and bearing (020) should be installed whenever the pump is rebuilt SAE 30 oil or equal should be used to assist pump reassembly. DO NOT USE GREASE.

**Step 1** – Install new "O" ring (016) and back-up ring (035) into groove on rotor housing (015). Position back-up ring on side of groove toward clamp ring slot. Install two piece clamp ring (036) into slot on rotor housing with the top half located on pin (042). Coat outside diameter of housing inboard end with oil and install into outlet cover (083). Secure clamp ring to outlet cover with capscrews (017). Lubricate capscrew threads and torque to 130 foot pounds  $\pm$  10 foot pounds.

**Step 2** – Refer to page 5 for reassembly of power rotor.

**Caution:** In handling the seal, do not let the carbon sealing washer drop. Take particular care not to scratch the lapped faces on the washer and stationary seal.

**Step 3** – Install new gasket furnished with mechanical seal into counterbore of outlet cover (083). Apply a light coat of oil and slide assembled power rotor into outlet cover. Bolt bearing retainer (008) to cover using capscrews (009), lubricate threads and torque to 25 foot pounds  $\pm$  2 foot pounds. Install oil seal (092) wet with oil, into counterbore of bearing retainer (wrap shim stock around shaft to cover keyway when installing the seal).

**Step 4** – Apply a light coat of oil and screw idler rotors (011) into housing. Bolt thrust plate (028) and spacers (041) to end of housing (015) using capscrews (027) with lubricated threads. Torque to 80 foot pounds  $\pm$  4 foot pounds.

**Step 5** – Both inlet head (002) and gasket (006) to assembled outlet cover (083) with capscrews and nuts (003) (004). Lubricate threads and torque to 53 pounds  $\pm$  2 foot pounds.

After reassembly, check that the rotors turn freely before placing pump into service. Check "Installation" section when installing pump and "Operation" section before starting pump.



Figure 1.

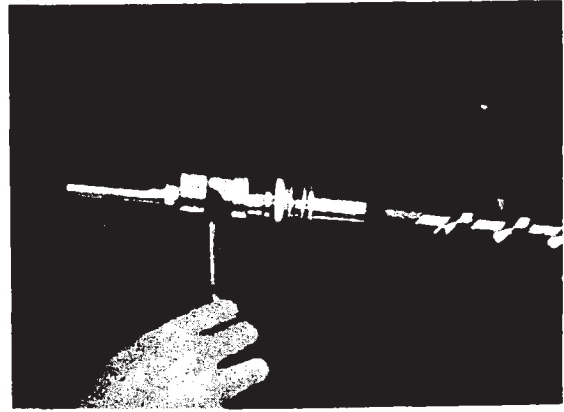

Figure 2.

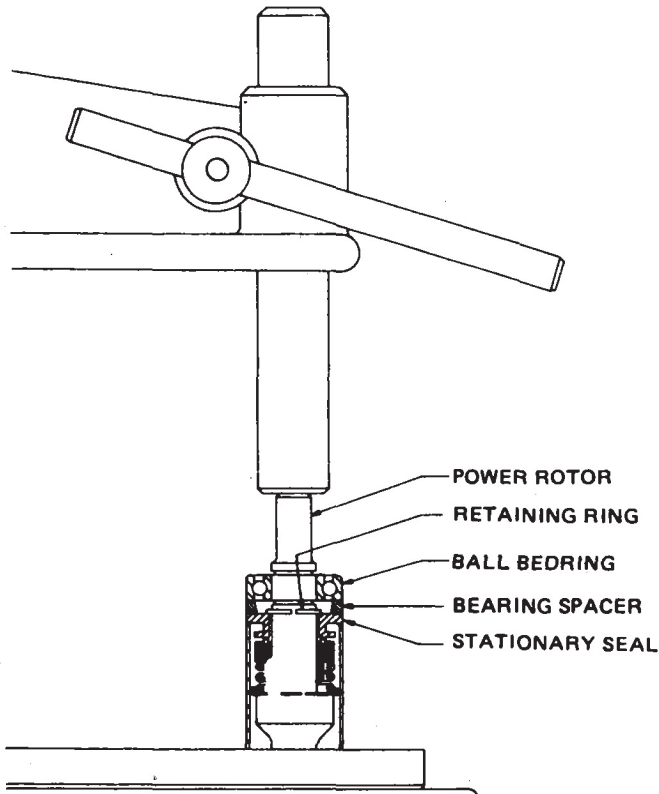

Figure 3.

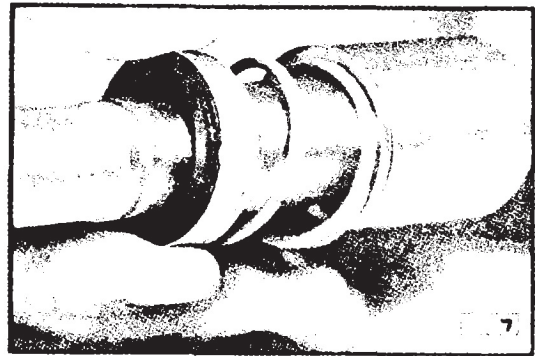

Figure 4.

#### DISASSEMBLY BEARING & MECHANICAL SHAFT SEAL 6U PUMPS

##### Step

1. If it is still in place, remove the coupling hub from the drive shaft.
2. Remove the outer retaining ring from the power rotor with a screw driver. (Fig. 1)
3. Remove the inner retaining ring from its groove by pulling back the mechanical seal and prying with a screw driver (Fig. 2).
4. Insert the power rotor assembly into a press and press off the bearing spacer and stationary seat of the mechanical seal - Fig. 3).
5. Remove seal subassembly (Fig. 4) and gasket from under the stationary seat.
6. Inspect the shaft. If the shaft is pitted or badly scratched or the retaining ring grooves damaged, replace the power rotor.
7. Discard the old seal, bearing and retaining rings

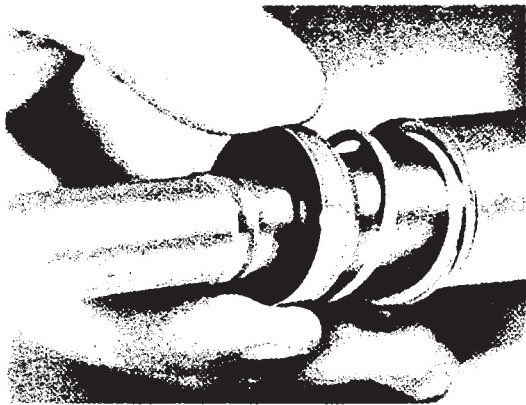

Figure 5.

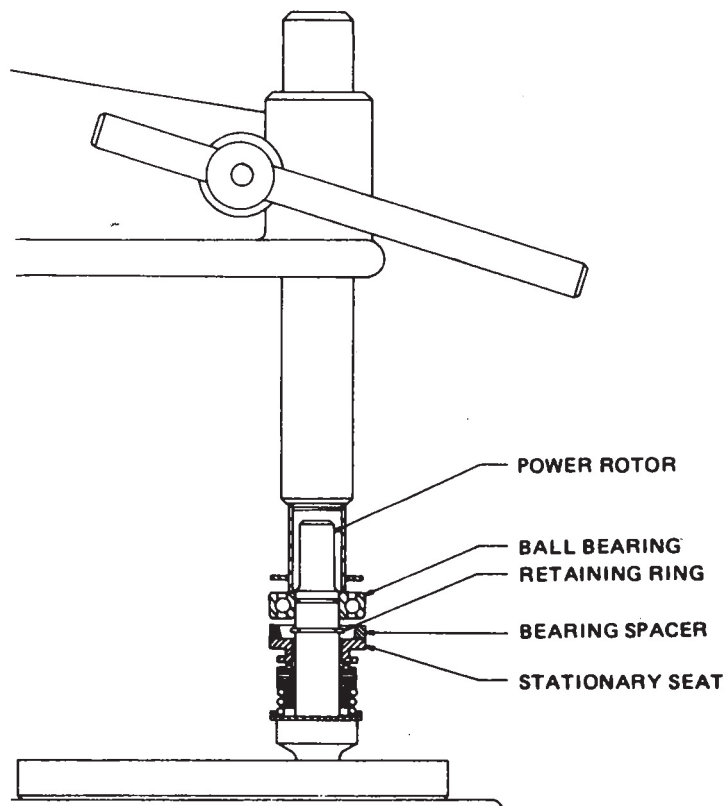

Figure 6.

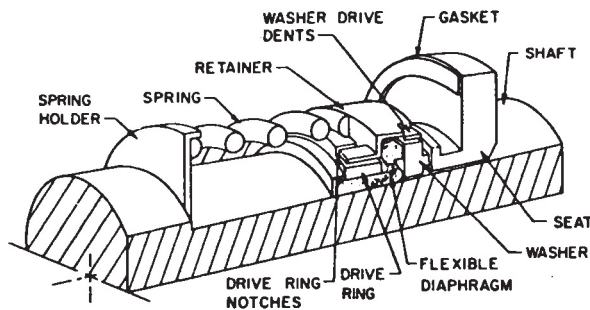

Figure 7.

**ASSEMBLY  
BEARING & MECHANICAL SHAFT SEAL  
6U PUMPS**

**Step**

1. Clean the power rotor shaft and snap ring grooves prior to installing the new seal and bearing. Wash the shaft in solvent to remove dirt and grease. Use only new bearing, seal, and retaining rings.
2. Place the spring holder and spring on the shaft.
3. Lubricate the shaft with clean, 500 ssu, hydraulic fluid.
4. Grasp the seal subassembly as shown in Fig. 5 and, using a rotating motion, gently slide the seal subassembly over the shaft. Use care not to cut the flexible diaphragm and drive ring. A piece of shim stock wrapped around the power rotor shaft to cover the snap ring grooves and shoulder of the seal diameter may be used for this purpose. If shim stock is used, twist the seal subassembly in the same direction as the wrap of the shim stock when installing it.
5. Install the seat with gasket and bearing spacer.
6. Install the inner retaining ring.
7. Place the ball bearing on the shaft. Using a hollow tube and *pressing on the inner race*, seat the bearing firmly against the snap ring (Fig. 6). **DO NOT PRESS THE BEARING ON THE OUTER RACE.**
8. Check the mechanical seal. Referring to Fig. 7, the flexible diaphragm must show evenly above the drive ring, and the drive lugs on the retainer must engage the drive ring to their full length. Adjust the mechanical seal if necessary.
9. Install the outer snap ring.
10. Lubricate the threads and install the power rotor assembly into the outlet cover (001).

## PARTS LIST

Drawing SD-5454

<u>NO.</u>	<u>NAME</u>	<u>NO.</u>	<u>NAME</u>	<u>NO.</u>	<u>NAME</u>
001	Outlet Cover - Flange	020	Ball Bearing X	081	Tubing
002	Inlet Head	021	Retaining Ring X (2)	082	Pipe Plug
003	Capscrew (8)	022	Key	084	Coupling XX
004	Nut (8)	027	Capscrew (2)	085	Setscrew (2)
006	Gasket X	028	Thrust Plate XX	086	Lip Seal (2) X
007	Bushing XX	031	Name Plate	087	Seal Housing
008	Bearing Retainer	032	Rivet (2)	088	Dowel Pin (2)
009	Capscrew (4)	035	Back-Up Ring X	091	Capscrew (6)
010	Power Rotor XX	036	Clamp Ring XX	092	Oil Seal X
011	Idle Rotor XX (2)	041	Spacer (2)	093	Taper Pull Pin (2)
014	Idle Stop XX	042	Spring Pin XX	094	Nut (2)
015	Rotor Housing XX	043	Spacer	095	Capscrew (4)
016	"O" Ring X	044	Capscrew (2)	096	Retainer
017	Capscrew (16) XX	045	End Cover (Outboard)	097	"O" Ring X
018	Mechanical Seal X	046	Gasket X (2)		
019	Spacer XX	080	Ermeto M. Conn.		

All parts marked X make up a minor Repair Kit  
 All parts marked X & XX make up a major Repair Kit  
 All quantities are one unless marked in parentheses

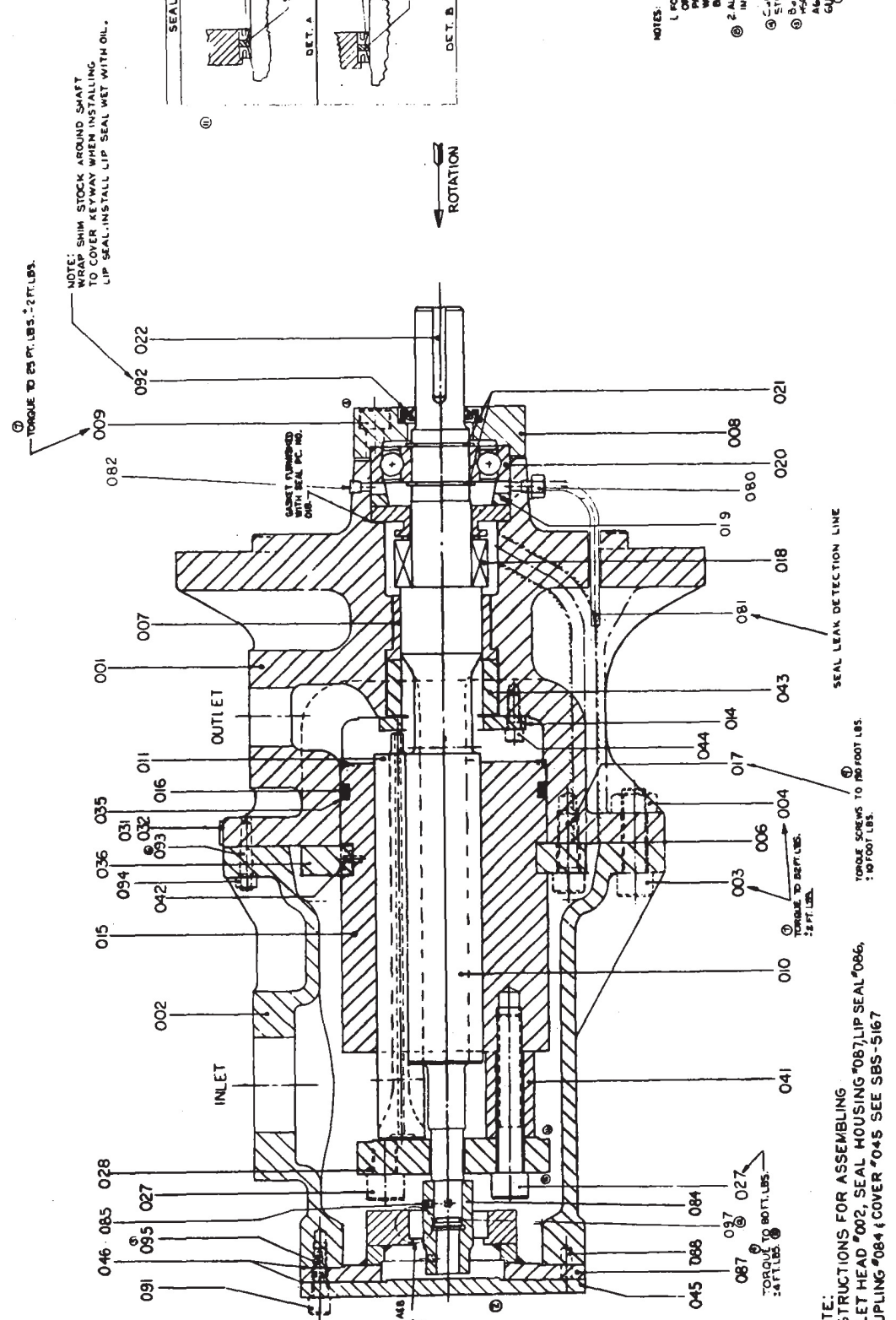

NOTE: SHIM STOCK AROUND SHAFT  
TO COVER KEYWAY WHEN INSTALLING  
LIP SEAL. INSTALL LIP SEAL WET WITH OIL.

① TORQUE TO 25 FT. LBS. ± 2 FT. LBS.

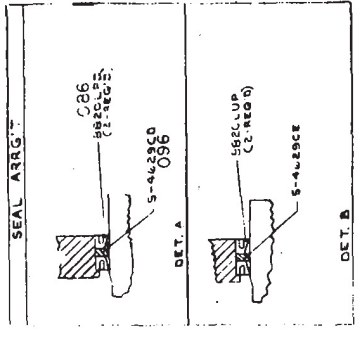

- NOTES:
- ① FOR PART DESCRIPTION SEE STD. DRAWING
  - ② ALL SCREWS 1 BOLTS MUST BE INSTALLED LUBRICATED WITH OIL.
  - ③ STEEL SCREWS 4 BOLTS 008 009 010 011 012 013 014 015 016 017 018 019 020 021 022 023 024 025 026 027 028 029 030 031 032 033 034 035 036 037 038 039 040 041 042 043 044 045 046 047 048 049 050 051 052 053 054 055 056 057 058 059 060 061 062 063 064 065 066 067 068 069 070 071 072 073 074 075 076 077 078 079 080 081 082 083 084 085 086 087 088 089 090 091 092 093 094 095 096 097 098 099 100 101 102 103 104 105 106 107 108 109 110 111 112 113 114 115 116 117 118 119 120 121 122 123 124 125 126 127 128 129 130 131 132 133 134 135 136 137 138 139 140 141 142 143 144 145 146 147 148 149 150 151 152 153 154 155 156 157 158 159 160 161 162 163 164 165 166 167 168 169 170 171 172 173 174 175 176 177 178 179 180 181 182 183 184 185 186 187 188 189 190 191 192 193 194 195 196 197 198 199 200 201 202 203 204 205 206 207 208 209 210 211 212 213 214 215 216 217 218 219 220 221 222 223 224 225 226 227 228 229 230 231 232 233 234 235 236 237 238 239 240 241 242 243 244 245 246 247 248 249 250 251 252 253 254 255 256 257 258 259 260 261 262 263 264 265 266 267 268 269 270 271 272 273 274 275 276 277 278 279 280 281 282 283 284 285 286 287 288 289 290 291 292 293 294 295 296 297 298 299 300 301 302 303 304 305 306 307 308 309 310 311 312 313 314 315 316 317 318 319 320 321 322 323 324 325 326 327 328 329 330 331 332 333 334 335 336 337 338 339 340 341 342 343 344 345 346 347 348 349 350 351 352 353 354 355 356 357 358 359 360 361 362 363 364 365 366 367 368 369 370 371 372 373 374 375 376 377 378 379 380 381 382 383 384 385 386 387 388 389 390 391 392 393 394 395 396 397 398 399 400 401 402 403 404 405 406 407 408 409 410 411 412 413 414 415 416 417 418 419 420 421 422 423 424 425 426 427 428 429 430 431 432 433 434 435 436 437 438 439 440 441 442 443 444 445 446 447 448 449 450 451 452 453 454 455 456 457 458 459 460 461 462 463 464 465 466 467 468 469 470 471 472 473 474 475 476 477 478 479 480 481 482 483 484 485 486 487 488 489 490 491 492 493 494 495 496 497 498 499 500 501 502 503 504 505 506 507 508 509 510 511 512 513 514 515 516 517 518 519 520 521 522 523 524 525 526 527 528 529 530 531 532 533 534 535 536 537 538 539 540 541 542 543 544 545 546 547 548 549 550 551 552 553 554 555 556 557 558 559 560 561 562 563 564 565 566 567 568 569 570 571 572 573 574 575 576 577 578 579 580 581 582 583 584 585 586 587 588 589 590 591 592 593 594 595 596 597 598 599 600 601 602 603 604 605 606 607 608 609 610 611 612 613 614 615 616 617 618 619 620 621 622 623 624 625 626 627 628 629 630 631 632 633 634 635 636 637 638 639 640 641 642 643 644 645 646 647 648 649 650 651 652 653 654 655 656 657 658 659 660 661 662 663 664 665 666 667 668 669 670 671 672 673 674 675 676 677 678 679 680 681 682 683 684 685 686 687 688 689 690 691 692 693 694 695 696 697 698 699 700 701 702 703 704 705 706 707 708 709 710 711 712 713 714 715 716 717 718 719 720 721 722 723 724 725 726 727 728 729 730 731 732 733 734 735 736 737 738 739 740 741 742 743 744 745 746 747 748 749 750 751 752 753 754 755 756 757 758 759 760 761 762 763 764 765 766 767 768 769 770 771 772 773 774 775 776 777 778 779 780 781 782 783 784 785 786 787 788 789 790 791 792 793 794 795 796 797 798 799 800 801 802 803 804 805 806 807 808 809 810 811 812 813 814 815 816 817 818 819 820 821 822 823 824 825 826 827 828 829 830 831 832 833 834 835 836 837 838 839 840 841 842 843 844 845 846 847 848 849 850 851 852 853 854 855 856 857 858 859 860 861 862 863 864 865 866 867 868 869 870 871 872 873 874 875 876 877 878 879 880 881 882 883 884 885 886 887 888 889 890 891 892 893 894 895 896 897 898 899 900 901 902 903 904 905 906 907 908 909 910 911 912 913 914 915 916 917 918 919 920 921 922 923 924 925 926 927 928 929 930 931 932 933 934 935 936 937 938 939 940 941 942 943 944 945 946 947 948 949 950 951 952 953 954 955 956 957 958 959 960 961 962 963 964 965 966 967 968 969 970 971 972 973 974 975 976 977 978 979 980 981 982 983 984 985 986 987 988 989 990 991 992 993 994 995 996 997 998 999 1000

NOTE: INSTRUCTIONS FOR ASSEMBLING  
INLET HEAD #002, SEAL HOUSING #087, LIP SEAL #086,  
COUPLING #084 & COVER #045 SEE SBS-5167

① TORQUE TO 25 FT. LBS. ± 2 FT. LBS.

② TORQUE TO 100 FT. LBS. ± 10 FT. LBS.

SEAL LEAK DETECTION LINE

ROTATION

GASKET FURNISHED WITH SEAL KIT NO. 008

SEE DET. A & B FOR SEAL ARR.





**CIRCOR**

1710 Airport Road  
PO Box 5020  
Monroe, NC USA  
28111.5020

Tel: +1. 877.853.7867

Email: [cc@circor.com](mailto:cc@circor.com)

Web: [www.circorpt.com](http://www.circorpt.com)

