



216 Series Twin-Screw Pump

Original Installation, Operation & Maintenance Manual

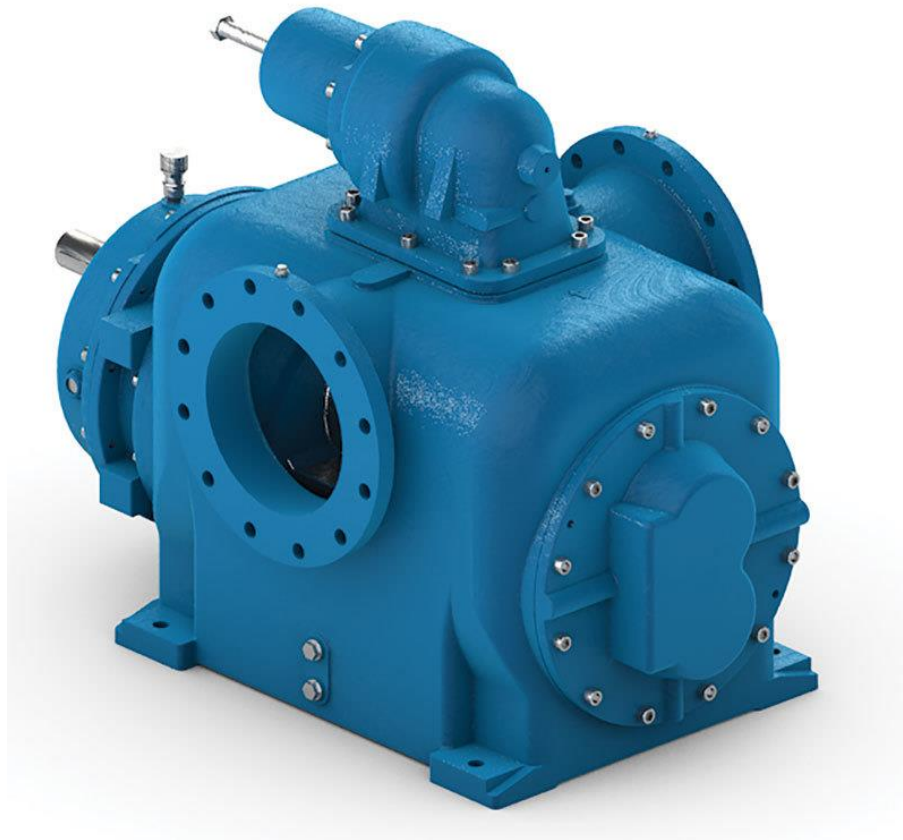

Table of Contents

Introduction and Safety	3
Introduction	3
Safety	3
Safety terminology and symbols	4
Environmental safety	5
User safety	6
Ex-approved products	8
Product warranty	15
Transportation and Storage	16
Inspect the delivery	16
Inspect the package	16
Inspect the unit	16
Transportation guidelines	16
Pump handling and lifting	16
Storage guidelines	18
Long-term storage	18
Product Description	20
General description	20
Nameplate information	22
Installation	24
Pre-installation	24
Pump location guidelines	24
Foundation requirements	25
Baseplate-mounting procedures	26
Prepare the baseplate for mounting	26
Prepare the foundation for mounting	27
Install the baseplate	27
Install the pump, driver, and coupling	28
Pump-to-driver alignment	28
Alignment checks	29
Allowable dial indicator values for alignment checks	30
Calculate the thermal expansion	30
Alignment measurement guidelines	32
Attach the dial indicators for alignment	32
Perform angular alignment for a vertical correction	33
Perform angular alignment for a horizontal correction	33
Perform parallel alignment for a vertical correction	34
Perform parallel alignment for a horizontal correction	35
Perform complete alignment for a vertical correction	36
Perform complete alignment for a horizontal correction	36
Grout the baseplate	37
Perform a final “soft foot” check	38
Pump Piping	39
General piping requirements and checklist	39
Suction-piping checklist	41
Discharge piping checklist	43
Auxiliary-piping checklist	43

Final piping checklist	44
Commissioning, Startup, Operation & Shutdown	45
Preparation for startup	45
Check the rotation	46
Couple the pump and driver	47
Bearing lubrication (216.40 pumps only)	48
Oil volume requirements (216.40 pumps only)	48
Lubricating-oil requirements (216.40 pumps only)	49
Lubricate the bearings with oil (216.40 pumps only)	49
Lubricate the gear/bearings after a shutdown period (216.40 pumps only)	49
Shaft sealing with a mechanical seal	50
How to prime the pump with the suction supply above the pump	50
Start the pump	50
Pump operation precautions	51
Shut down the pump	53
Make the final alignment of the pump and driver	53
Dowelling the driver (Optional)	54
Maintenance	55
Maintenance schedule	55
Bearing maintenance (216.40 pumps only)	56
Mechanical-seal maintenance	56
Disassembly	57
Disassembly precautions	57
Tools required	57
Prepare for disassembly	58
Disassembly of the 216.40 pump (standard component method)	58
Disassembly of the 216.10 pump (standard component method)	60
Preassembly inspections	61
Replacement guidelines	61
Screw shaft replacement guidelines	65
Bearings inspection	66
Reassembly of the 216.40 pump (standard component method)	68
Reassembly of the 216.10 pump (standard component method)	70
Spare parts	75
Minor Kit	75
Major Kit	75
Troubleshooting	78
Operation troubleshooting	78
Alignment troubleshooting	80
Supplemental assembly information	81
Maximum torque values for fasteners	81
Recommended torquing sequence for bolted joints	82

Introduction and Safety

Introduction

Purpose of this manual

The purpose of this manual is to provide necessary information for:

- Installation
- Operation
- Maintenance

**CAUTION:**

Failure to observe the instructions contained in this manual could result in personal injury and property damage and may void the warranty. Read this manual carefully before installing and using the product.

NOTICE:

Save this manual for future reference and keep it readily available.

Requesting other information

Special versions can be supplied with supplementary instruction leaflets. See the sales contract for any modifications or special version characteristics. For instructions, situations, or events that are not considered in this manual or in the sales documents, please contact the nearest CIRCOR representative.

Always specify the exact product type and identification code when requesting technical information or spare parts.

Safety

**WARNING:**

- The operator must be aware of the pumped fluid and take appropriate safety precautions to prevent physical injury
- Risk of serious injury or death. If any pressure-containing device is over-pressurized, it can explode, rupture, or discharge its contents. It is critical to take all necessary measures to avoid over-pressurization.
- Risk of death, serious personal injury, and property damage. Installing, operating, or maintaining the unit using any method not prescribed in this manual is prohibited. Prohibited methods include any modification to the equipment or use of parts not provided by CIRCOR. If there is any uncertainty regarding the appropriate use of the equipment, please contact an CIRCOR representative before proceeding.
- Risk of serious personal injury. Applying heat to parts with internal cavities or reliefs can cause trapped liquid to rapidly expand and result in a violent explosion. This manual clearly identifies accepted methods for disassembling units. These methods must be adhered to. Never apply heat to aid in part removal unless it is explicitly stated in this manual.

- If the pump or motor is damaged or leaking, electric shock, fire, explosion, toxic release, physical harm, or environmental damage may result. Do not operate the unit until the problem has been corrected or repaired.
- Risk of serious personal injury or property damage. Dry running may cause rotating parts within the pump to seize to non-moving parts. Do not run dry unless the pump is specifically supplied to support a dry run condition.
- Risk of death, serious personal injury, and property damage. Heat and pressure buildup can cause explosion, rupture, and discharge of the pumped fluid. Never operate the pump with discharge and/or suction valves closed.
- Running a pump without safety devices exposes operators to risk of serious personal injury or death. Never operate a unit unless appropriate safety devices (pressure relief valves, guards, etc.) are properly installed. See specific information about safety devices in other sections of this manual.

**CAUTION:**

Risk of injury and/or property damage. Operating a pump in an inappropriate application can cause over pressurization, overheating, and/or unstable operation. Do not change the service application without the approval of an authorized CIRCOR representative.





Safety terminology and symbols

About safety messages

It is extremely important that you read, understand, and follow the safety messages and regulations carefully before handling the product. They are published to help prevent these hazards:

- Personal accidents and health problems
- Damage to the product
- Product malfunction

Hazard levels

Hazard level	Indication
 DANGER:	A hazardous situation which, if not avoided, will result in death or serious injury
 WARNING:	A hazardous situation which, if not avoided, could result in death or serious injury
 CAUTION:	A hazardous situation which, if not avoided, could result in minor or moderate injury
 NOTICE:	<p>A potential situation which, if not avoided, could result in undesirable conditions or equipment damage</p> <p>A practice not related to personal injury</p>

Hazard categories

Hazard categories can either fall under hazard levels or let specific symbols replace the ordinary hazard level symbols.

Electrical hazards are indicated by the following specific symbol:



Electrical Hazard:

These are examples of other categories that can occur. They fall under the ordinary hazard levels and may use complementing symbols:

- Crush hazard
- Cutting hazard
- Arc flash hazard

The Ex symbol

The Ex symbol indicates safety regulations for Ex-approved products when used in atmospheres that are potentially explosive or flammable.



Environmental safety

The work area

Always keep the station clean to allow early discovery of any emissions due to a malfunction.

Waste and emissions regulations

Observe these safety regulations regarding waste and emissions:

- Appropriately dispose of all waste.
- Handle and dispose of the processed liquid in compliance with applicable environmental regulations.
- Clean up all spills in accordance with safety and environmental procedures.
- Report all environmental emissions to the appropriate authorities.



WARNING:

If the product has been contaminated in any way, such as from toxic/flammable chemicals or biological agents do NOT send the product to CIRCOR unless it has been properly decontaminated.

Electrical installation

For electrical installation recycling requirements, consult your local electric utility.

Recycling guidelines

Always follow local laws and regulations regarding recycling.

User safety

General safety rules

These safety rules apply:

- Always keep the work area clean.
- Pay attention to the risks presented by gas and vapors in the work area.
- Avoid all electrical dangers. Pay attention to risks of electric shock or arc flash hazards.
- Always bear in mind the risk of drowning, electrical accidents, and burn injuries.
- If operating temperatures exceed 60 °C (140 °F), measures must be taken to avoid skin contact

Safety equipment

Use safety equipment according with the company regulations. Use this safety equipment within the work area:

- Protective helmet
- Safety goggles, preferably with side shields
- Protective shoes
- Protective gloves
- Gas mask
- Hearing protection
- First-aid kit
- Safety devices

Electrical connections

Electrical connections must be made by certified electricians in compliance with all international, national, state, and local regulations. For more information about requirements, see sections dealing specifically with electrical connections.

Precautions before work

Observe these safety precautions before you work with the product or are in connection with the product:

- Provide a suitable barrier around the work area, for example, a guard rail.
- Make sure that all safety guards are in place and secure.
- Make sure that you have a clear path of retreat.
- Make sure that the product cannot roll or fall over and injure people or damage property.
- Make sure that the lifting equipment is inspected and in good condition.
- Use a lifting harness, a safety line, and a breathing device as required.
- Allow all system and pump components to cool before you handle them.
- Make sure that the product has been thoroughly cleaned.
- Disconnect and lock out power before you service the pump.
- Check the explosion risk before you weld or use electric hand tools.

Precautions during work

Observe these safety precautions when you work with the product or are in connection with the product:



CAUTION:

Failure to observe the instructions contained in this manual could result in personal injury and property damage and may void the warranty. Read this manual carefully before installing and using the product.

- Always wear the appropriate PPE.
- Never work alone.
- Stay well clear of suspended loads.
- Always lift the product by its lifting device(s).
- Beware of the risk of a sudden start if the product is used with an automatic control.
- Rinse the components in water or a solvent as directed after you disassemble the pump.
- Never exceed the maximum working pressure of the pump.
- Never disable, remove or bypass the pump safety pressure relief valve
- Do not open any vent or drain valve or remove any plugs while the system is pressurized. Make sure that the pump is isolated from the system and that pressure is relieved before you disassemble the pump, remove plugs, or disconnect piping.
- Never operate a pump without a properly installed coupling guard.
-  The coupling guard used in an ATEX classified environment must be constructed from a non-sparking material.

Airborne Noise

Airborne Noise of the pump is dependent on the application parameters and where it exceeds 70 dB(A) appropriate safety measures must be taken to prevent injury. The specific sound pressure level of each pump is included in a datasheet provided to the customer along with this manual.

Hazardous liquids

The product is designed for use in liquids that can be hazardous to your health. Observe these rules when you work with the product:

- Make sure that all personnel who work with biologically hazardous liquids are vaccinated against diseases to which they may be exposed.
- Observe strict personal cleanliness.
- A small amount of liquid will be present in certain areas like the seal chamber and cavities which cannot be fully drained due to the pump geometry.

Wash the skin and eyes

Follow these procedures for chemicals or hazardous fluids that have come into contact with your eyes or your skin:

Condition	Action
Chemicals or hazardous fluids in eyes	<ol style="list-style-type: none"> 1. Hold your eyelids apart forcibly with your fingers. 2. Rinse the eyes with eyewash or running water for at least 15 minutes. 3. Seek medical attention.
Chemicals or hazardous fluids on skin	<ol style="list-style-type: none"> 1. Remove contaminated clothing. 2. Wash the skin with soap and water for at least 1 minute. 3. Seek medical attention, if necessary.

Ex-approved products

These additional instructions apply to applications where Pumps have been evaluated for use in potentially explosive atmospheres according to Directive 2014/34/EU (ATEX) and are additional requirements to the Safety and Operation, Installation, General Maintenance and Troubleshooting sections of this manual.

Section Contents:

Section 1 – For Your Safety (Proper Use, Operators Obligations, Materials and Liquids)

Section 2 – Explosion protection labeling (Explosion protection marking for group II category 2 and 3)

Section 3 – Installation and commissioning (Category 2 and 3).

Section 4 – Points to note during operation of pump (Operation, Maintenance, Additional measures for dust)

1. For Your Safety:

Pump is manufactured in accordance with latest state-of-the-art safety regulations. However, danger to life and limb of user and third parties and damages to pump can arise during operation. To ensure optimal and safe operation of pump, maintenance must be carried out by appropriately qualified expert personnel. Work on electrical equipment must be carried out by authorized electricians in accordance with respective national standards and electrical technology guidelines.

1.1 Operators Obligations

- Evaluate and document the location, where the system is to be operated, and dangers from explosions in accordance with directive Evaluate and document the operating areas of the system for danger of explosions in accordance with Directive 99/92/EC, Annex I.
- Ensure that directive 99/92/EC, to protect the health and safety of the employee in potentially explosive atmospheres, is maintained.
- Only use the pump as allowed by the explosion protection nameplate.
- Always ensure the following.

- The pump is grounded.
 - There is no contact between the coupling and coupling guard
 - Pump interior, seal chamber, auxiliary systems, inlet and outlet piping, are always completely filled with the liquid being pumped.
 - The maximum permissible surface temperature of the pump is not exceeded.
 - The maximum permissible fluid medium temperature is not exceeded (see 2.3)
 - Valves on the inlet and outlet of the pump are set correctly.
 - The pump has regular maintenance and monitoring.
 - It is impossible for the pump to run dry i.e, by monitoring tank levels, flow measurements, etc.
- Ensure that the motors, couplings, gears and monitoring equipment supplied on site correspond to the category and temperature class of the associated zone.
 - Note the information on order data sheet
 - Inform personnel regarding special dangers
 - Danger of explosions through removal of dust buildup
 - All users must know about the risks of electric current and the chemical and physical characteristics of the gas, the vapor, or both present in hazardous areas.
 - Any maintenance for Ex-approved products must conform to international and national standards (for example, IEC/EN 60079-17).
 - CIRCOR disclaims all responsibility for work done by untrained and unauthorized personnel.
 - The yield stress of fasteners must be in accordance with the approval drawing and the product specification.
 - Do not modify the equipment without approval from an authorized CIRCOR representative.
 - Only use parts that are provided by an authorized CIRCOR representative.



1.2 Materials:

All pump parts and accessories must consist of electrically conductive materials.

With combustible pumped liquids, all pressure bearing parts must be of ductile material from internal pump pressures of 10 bar (145 psi) or greater.

2. Explosion Protection Labeling

2.1 Temperature class and type of explosion protection marking are on nameplate.

  II 3G Ex h IIC T4...T1 Gc X

 _____ CE Label

 _____ Symbol for explosion protected equipment

II _____ Equipment group per Directive 2014/34/EU is other than underground

3 _____ Equipment Category (section 2.2 below)

G _____ Explosion Atmosphere (G = Gas)

h _____ Ignition protection reference (see 2.4 below)

T4...T1 _____ Temperature class (see 2.3 below for Special Use Conditions)

X _____ Ambient Temperature (see 2.5 below for Special Use Conditions)

2.2 Category

Category 2 - The frequency of occurrence of dangerous potentially explosive atmospheres is only occasional (any faults occurring must not become a source of ignition)

Category 3 - The frequency of occurrence of dangerous potentially explosive atmospheres is unlikely and can occur only rarely and for a short time

1. The pump guarantees a normal level of protection.
2. No unacceptable high surface temperatures may become an ignition risk during normal operation.

2.3 Temperature Class – Flammable gases and vapors are divided into temperature classes for their flammability on hot surfaces. Surface temperature of pump must always be less than lowest ignition temperature in the temperature class.

Classification of maximum surface temperature for Group II Equipment

Temperature Class on Accordance with EN 80079-36	Maximum Surface Temperature
T4	135 °C (275°F)
T3	200 °C (392°F)
T2	300 °C (572°F)
T1	450 °C (842°F)

Special Use Condition- Marking T4...T1

The maximum surface temperature depends on operating conditions. Refer to the Declaration of Conformity for T code and Maximum Fluid Temperature indicated.

Special Use Condition – In certain pumps with mechanical seals the maximum permissible medium temperature must not be exceeded. Refer to the Declaration of Conformity for the maximum permissible medium temperature.

2.4 Ignition Protection Reference:

Type of Protection for non-electrical equipment	Meaning
b	Ignition source monitoring for category 2 applications
c	Safe design constructional safety
h	Mark for non-electrical equipment (not a protection method)

2.5 Ambient Temperature:

Special Use Conditions-

The pumps conform to the ambient temperature service range specified by the application parameters provided by the customer. Please refer to the Declaration of Conformity for the ambient temperature range. If no range is provided, the normal ambient temperature of $-20\text{ °C} \leq T_a \leq +40\text{ °C}$ ($-4\text{ °F} \leq T_a \leq +104\text{ °F}$) applies.

3) ATEX Measures

3.1 Installation and connection of pump (Measures depend upon category.)

3.1.1 Category 3

- 1 Stay within the maximum permissible temperature of the pumped fluid on the order data sheet.
- 2 Prevent overheating when operating in a circulating system by routing the return line from the safety valve to the tank not into the suction pipe
- 3 For couplings with coupling guards:
 - a. Only use guards made from electrically conductive materials
 - b. Secure the setscrews to fix the coupling halves to the guards with medium strength thread retaining compound.
 - c. For aluminum guards, remove swarf and dirt from coupling guard
- 4 Ignition protection type is c = structural safety. (No additional monitoring equipment is required.)
- 5 For Pumps with motors supplied by the operator, motors must correspond to the requirements in the explosion hazard area (group and category).
- 6 Earthing Terminals must be provided for pump units, including base plate and motor.

3.1.2 Category 2

- 1 Ensure there is monitoring equipment to prevent dry running. (ex. Tank level switch)
This equipment shall have a suitable level of reliability and installed with established safety principles able to withstand expected influences during operation. This equipment shall provide adequate warning that dry running can develop, must be capable of being checked at suitable intervals and include the detection of loss of safety function. The equipment manufacturer's use instructions shall specify the interval between periodic maintenance checks and include advise on methods for detecting failure modes and actions to be taken to remedy. (Ref. EN 80079-37 Clause 6.5.1)
- 2 Ensure there is monitoring equipment to avoid overheating.
 - If the system controller is not suitable for monitoring, install power monitor.
 - Set monitoring according to:
 - The pumping parameters
 - The characteristic curve of the pump
 - The motor manufacturers' specifications

- 3 If pumped fluid is contaminated with solid particles:
 - a. Install temperature sensor on case surface
 - b. Adjust temperature monitoring device according to the manufacturer's specifications and to the maximum allowable temperature of the housing surface by its temperature class.

- 4 For pumps with separate relief valves:
 - a. Install a pressure relief valve in the pressure line and adjust it accordingly
 - b. Provide a return line into the tank

3.2 Operation

3.2.1 Stay within the maximum permissible surface temperature

Pumped liquid

Stay within the maximum permissible temperature on the order data sheet

Housing surface (Only relevant to category 2)

If the pumped liquid is contaminated with solid particles, monitor the temperature of the case surface so that maximum permissible temperature of the housing surface does not go higher than permissible by the temperature class on the nameplate.

3.2.2 Avoid Overheating (Only relevant to category 2)

Overheating results from the impermissible operating conditions of:

- a. Dry Running
- b. Operating pump while the pressure side valve is closed.
- c. Operating pump while inlet side valve is closed
- d. Operating outside the pumps design parameters

Monitor motor power to detect the above problems with overheating.

3.2.3 Do not operate in an explosive atmosphere. (Only relevant to category 2)

If an explosive atmosphere occurs, switch off pump

3.3 Maintenance (Reduce maintenance intervals for more difficult operating conditions.)

3.3.1 Maintenance to perform

1. Check at appropriate intervals:
 - Motor and pump couplings according to manufacturer's operating instructions
 - Deformation of guard around coupling and spacing to rotating parts
 - Functioning of monitoring devices
 - Surface temperature of pump and motor
 - Entire unit for excess vibrations
 - Pump during operation for altered running noises
 -
2. Change at appropriate intervals:
 - a. Change seal when leakage exceeds 5 drops per hour.
 - b. Change Spherical roller bearings every 25000 hours if found to be overheating or noisy.

4. Additional measures for category 2

1. Periodically remove dust build up before thickness gets to 5 mm (0.2 in).
2. Remove swarf and dirt from on and below the coupling guards.

Monitoring equipment

For additional safety, use condition-monitoring devices. Condition-monitoring devices include but are not limited to these devices:

- Pressure gauges / transducers / switches
- Flow meters / switches
- Level indicators / transducers / switches
- Motor power measurement
- Temperature indicators / transducers / switches
- Vibration transducers / switches
- Leak detectors / switches
- Suction filter(s)

Product warranty

Coverage

CIRCOR undertakes to remedy faults in products from CIRCOR under these conditions:

- The faults are due to defects in design, materials, or workmanship.
- The faults are reported to a CIRCOR representative within the warranty period.
- The product is used only under the conditions described in this manual.
- The monitoring equipment incorporated in the product is correctly connected and in use.
- All service and repair work is done by CIRCOR-authorized personnel.
- Genuine CIRCOR parts are used. Only Ex-approved spare parts and accessories authorized by CIRCOR are used in Ex-approved products.

Limitations

The warranty does not cover faults caused by these situations:

- Deficient maintenance
- Improper installation
- Modifications or changes to the product and installation made without consulting CIRCOR
- Incorrectly executed repair work
- Normal wear and tear

CIRCOR assumes no liability for these situations:

- Bodily injuries
- Material damages
- Economic losses

Warranty claim

CIRCOR products are high-quality products with expected reliable operation and long life. However, should the need arise for a warranty claim, then contact your CIRCOR representative.

Transportation and Storage

Inspect the delivery

Inspect the package

1. Inspect the package for damaged or missing items upon delivery.
2. Note any damaged or missing items on the receipt and freight bill.
3. File a claim with the shipping company if anything is out of order.
4. If the product has been picked up at a distributor, make a claim directly to the distributor

Inspect the unit

1. Remove packing materials from the product.
Dispose of all packing materials in accordance with local regulations.
2. Inspect the product to determine if any parts have been damaged or are missing.
3. If applicable, unfasten the product by removing any screws, bolts, or straps. For your personal safety, be careful when you handle nails and straps.
4. Contact your sales representative if anything is out of order.

Transportation guidelines

Pump handling and lifting

Precautions for moving the pump

Use care when moving pumps. Consult with a lifting and rigging specialist before lifting or moving the pump to avoid possible damage to the pump or injury to personnel.

**WARNING:**

Dropping, rolling or tipping units, or applying other shock loads, can cause property damage and personal injury. Ensure that the unit is properly supported and secure during lifting and handling.

**CAUTION:**

Risk of injury or equipment damage from use of inadequate lifting devices. Ensure that all lifting devices such as chains, straps, lifting beams, fixtures, forklifts, cranes, etc. are rated to a sufficient capacity.

Precautions for lifting the pump

**WARNING:**

Dropping, rolling or tipping units, or applying other shock loads, can cause property damage and personal injury. Ensure that the unit is properly supported and secure during lifting and handling.

Risk of serious personal injury or equipment damage. Proper lifting practices are critical to safe transport of heavy equipment. Ensure that practices used are in compliance with all applicable regulations and standards.

Lifting and handling heavy equipment poses a crush hazard. Use caution during lifting and handling and wear appropriate Personal Protective Equipment (PPE, such as steel-toed shoes, gloves, etc.) at all times. Seek assistance if necessary.

Safe lifting points are specifically identified in this manual. It is critical to lift the equipment only at these points. Unless otherwise indicated on the GA or Outline drawing, integral lifting eyes or eye bolts on pump and motor components are intended for use in lifting the individual components only.

Transportation and Storage

**NOTICE:**

Make sure that the lifting equipment supports the entire assembly and is only used by authorized personnel.

Do not attach slings, chains or ropes to shaft ends.

Lifting the pump

If the pump is equipped with lifting eyes **AND** these are specifically identified on the pump GA or outline drawing as suitable for lifting the pump then proceed as follows: Lift the pump as shown in Figure 1 below, using suitable slings, ropes or chains attached to the lifting eyes.

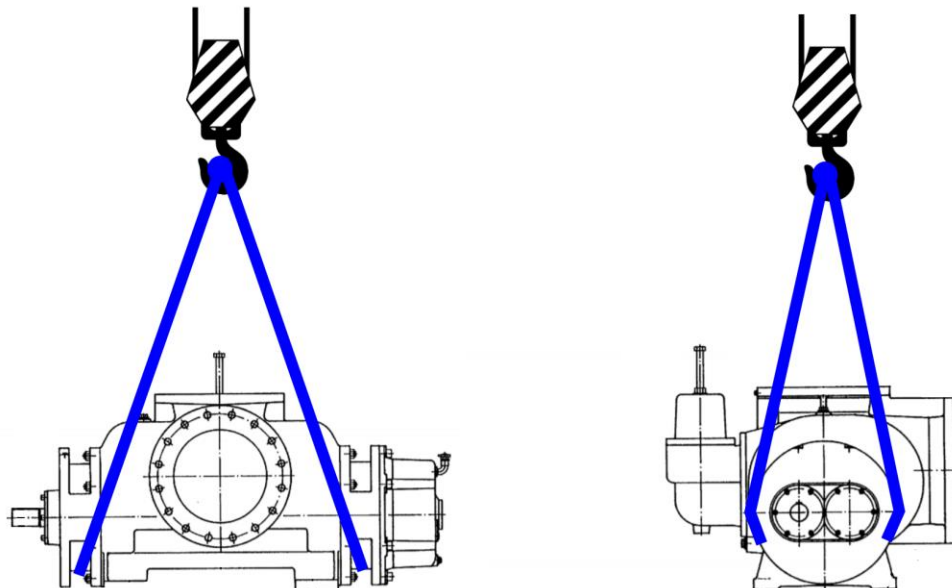

Figure 1: Example of the proper lifting method for a bare pump

Baseplate-mounted units have lifting points for use with proper lifting devices. These lifting points should be utilized as instructed on the unit GA or outline drawing

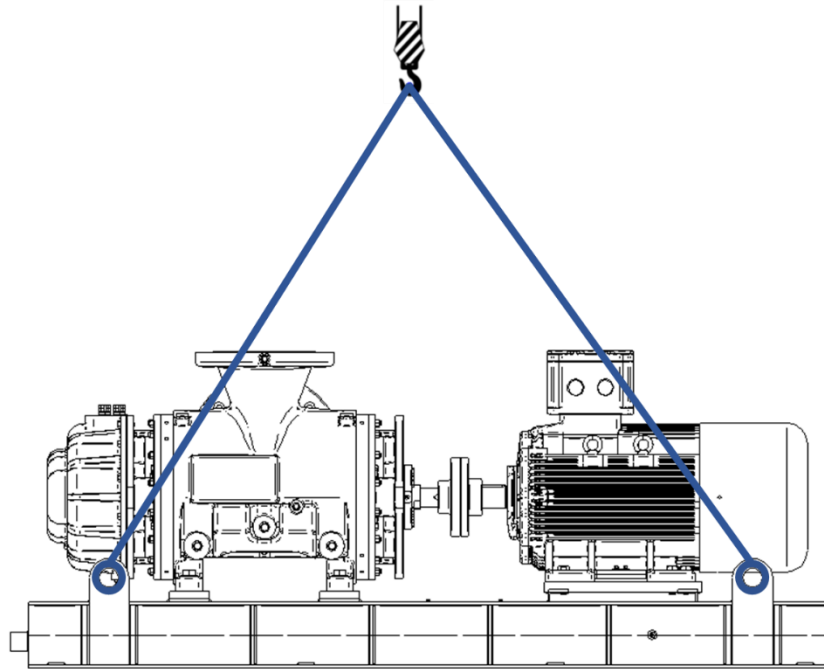

Figure 2: Example of the proper lifting method for baseplate-mounted units with a driver

Storage guidelines

Long-term storage

Units are shipped on skids and suitably boxed or crated to prevent damage from normal handling. All exterior, unpainted surfaces subject to corrosion are coated with a rust preventive compound. Pump openings are covered with blank flanges or special covers.

A packing list is furnished itemizing the contents of the shipment. When received, check the contents against the packing list. Report any discrepancies to CIRCOR or your local CIRCOR distributor immediately.

If pump is not to be immediately installed and operated and will be stored for more than 6 months, or if pump is not to be operated for some time after installation, the unit must be cared for as follows:

1. Select a clean dry storage location.
2. Be certain that blank flanges or cups covering pump openings are properly attached.
3. Store the unit free from heat, dirt, and vibrations.
4. Rotate pump shaft through several turns at least monthly.
5. If area where pump is stored or installed is a humid or dusty atmosphere:
 - Recoat all exterior, unpainted surfaces subject to corrosion with a rust-inhibiting compound.
 - Fill oil reservoirs completely full of oil. It is recommended that a tag be attached to the housing indicating that it is full of oil.
 - Protect pump and driver with a plastic or canvas covering.

Fill cast iron or carbon steel pumps with oil. As an alternative the interior surfaces of the pump can be misted with a suitable rust inhibiting compound and bagged desiccant placed in accessible locations inside the pump. It is recommended that a tag be attached to the pump indicating what internal preservation (e.g. filling with oil) has been made as well as the locations of any desiccant bags.

Refer to the drive unit and coupling manufacturers for their long-term storage procedures.

For questions about possible long-term storage treatment services, please contact your local CIRCOR sales representative.

Product Description

General description

Product description

The Houttuin 216 Series geared twin screw pump is a rotary positive displacement pump which consists of two counter-rotating screw shafts. The screws on these shafts mesh retaining a limited clearance and rotating freely inside the liner or pump casing bores.

This creates a vacuum (under pressure) that causes the fluid to flow towards the pump. The pumped fluid enters through the suction inlet, the flow is divided and enters at the ends of the pump and travels to the center of the pump and discharge. The center part of the cylinders has an open connection towards the discharge.

The torque is transmitted from the driver through the driven screw shaft to the short shaft by means of the timing gears. Both shafts are supported by bearings and are axially fixed at the non-driven end of the shafts. The bearings are not subjected to any load because of the hydraulic axial balance between the screws.

Casing – The casing is foot mounted with side -suction and top discharge nozzle. 216 series are equipped with DIN EN 1092-1, PN16, PN25, PN64 / ASME B16.5 150lbs, 300lbs and 600lbs flanges. The solid cast body has thick cross sections for rigidity. Body passages are designed to eliminate dead spaces to prevent liquid stagnation. Direct flow path from suction opening to entrance of pumping screws has hydraulically wide open to improve efficiency and NPSH behavior. The result is more uniform velocity changes for lower entrance friction losses and consequently higher suction lift capabilities.

Liner The field replaceable liner is manufactured in one piece with the material and surface treatment selected specifically to match the metallurgy of the screws and the fluid being pumped. The openings in the liner are engineered to improve NPSH behavior while at the same time achieving the necessary rigidity in operation.

Screw/Shaft Shafts and screws are manufactured as one robust integral rotor unit allowing for maximum rigidity and stiffness. This minimizes shaft deflection, an important consideration in high-pressure service. Screw block root diameter are reduced for greater displacement.

Seal Chamber – The seal chamber(s) are under suction pressure only. The 216.40 pump has four seal chambers. The 216.10 has one seal chamber. They are designed to accommodate standard single seals in a component configuration. The standard API 682 seal plan provided is 03.

Bearing Brackets – Bearing bracket are round type with rigid ribs to withstand greater torsional load. Bearing bracket are sealed off from the environment by lip seal. Bearing brackets are isolated and lubricated to protect the bearings. The brackets may be furnished with provisions for temperature and/or vibration sensors.

Timing Gears – Timing gears are used to transmit power from the drive to the idler shaft and to prevent metal contact between the meshed, rotating screws. The "timing" or placement of the gears on the shaft prevents rotational contact of the pumping screws. This clearance between the pumping screws relates to extended pump life and higher, average efficiency over the life of the pump. Spur gear are used for transmission. For the 216.40, the gears are oil lubricated by means of a self-contained system and are sealed off from the environment by lip seals. For the 216.10, the gears are lubricated by the pumped product. The gears are of steel construction.

Bearings – Radial loading is handled at four locations by heavy-duty rolling element bearings that are sized to handle maximum loads. For the 216.40, the bearings are oil lubricated at gear side and either grease or oil lubricated at motor side and sealed off from the pumped fluid by lip seals. For the 216.40, all bearings are lubricated by the pumped product. The pump is hydro dynamically balanced, so axial loading is eliminated.

Baseplate

The fabricated steel baseplate supports the pump, driver, and accessories in accordance with CIRCOR standards or API-676 latest Edition requirements depending on application.

Direction of rotation

The direction of rotation is normally clockwise when viewed look at the drive end of the pump. The direction of rotation furnished on a specific order should be verified by checking the pump GA or outline drawing or the direction of rotation arrow affixed to the pump.

Nameplate information

Important information for ordering

Every pump has a nameplate that provides information about the pump. The nameplate is located on the pump casing.

When you order spare parts, identify this pump information:

- Model
- Size
- Serial number
- Item numbers of the required parts

Item numbers can be found in the spare parts list.

Refer to the nameplate on the pump casing for most of the information. See Parts List for item numbers.

Nameplate types

Nameplate	Description
Pump	Provides information about the hydraulic characteristics of the pump. For 216 pumps the pumps size is designated in steps from smallest (088) to Largest (225). For example, a 216.10 size 225 pump with a 120mm (4.7") screw pitch would be: 216.10.225-120 .
ATEX	If applicable, your pump unit might have an ATEX nameplate affixed to the pump, the baseplate, or the discharge head. The nameplate provides information about the ATEX specifications of this pump.

Nameplate on the pump casing

|

653/1, 22, SOMNATH CO-OP
 IND SOCIETY, DAMAN, INDIA.

CE II 3G
 Ex h IIC T4...T1 Gc X

SIZE/TYPE ITEM NO.

SERIAL NO. ORDER

	MINIMUM	MAXIMUM	UNITS
DESIGN PRESS	<input type="text" value="-"/>	<input type="text" value="-"/>	<input type="text" value="-"/>
DESIGN TEMP	<input type="text" value="-"/>	<input type="text" value="-"/>	<input type="text" value="-"/>
SPEED	<input type="text" value="-"/>	<input type="text" value="-"/>	<input type="text" value="-"/>
CAPACITY	<input type="text" value="-"/>	<input type="text" value="-"/>	<input type="text" value="-"/>
POWER	<input type="text" value="-"/>	<input type="text" value="-"/>	<input type="text" value="-"/>

MAWP MAWT

HYDROSTATIC TEST PRESSURES

CASING PUMP

CRITICAL SPEED YEAR

Figure 4: Nameplate on the pump casing using SI or US units

Nameplate field	Explanation
PUMP SIZE /TYPE	Size of the pump and any specific type identifiers
ITEM NO.	The pump BOM #
SERIAL NO.	The CIRCOR /Houttuin assigned serial number
ORDER	The customer order number or reference
DESIGN PRESSURE	Range of pressure the pump is designed for when considering both maximum and minimum temperature
TEMPERATURE	Rated pump minimum and maximum temperature
SPEED	Rated pump speed range, in revolutions per minute
CAPACITY	The minimum and maximum pump flowrate when considering speed, temperature, pressure and fluid viscosity.
POWER	The minimum and maximum pump power when considering speed, temperature, pressure and fluid viscosity.
MAX. ALLOWABLE WORKING PRESSURE	Highest allowable working pressure when considering both maximum and minimum temperature
MAX. ALLOWABLE WORKING TEMPERATRUE	Highest allowable working temperature at maximum allowable working pressure
CRITICAL SPEED	The speed at which the pump screws exhibit their 1 st lateral natural frequency in revolutions per minute
HYDRO TEST PRESSURE	The hydrostatic pressure at 38°C (100°F) of the casing and assembled pump respectively
UNITS	The unit of measure utilized for the values of pressure, temperature and flow

ATEX nameplate



Figure 5: ATEX nameplate (generic example)

Nameplate field	Explanation
II	Group 2
2	Category 2
G/D	Pump can be used when gas and dust are present
T4	Temperature class



WARNING:

Use of equipment unsuitable for the environment can pose risks of ignition and/or explosion. Ensure that the code classifications on the pump are compatible with the specific environment in which the equipment is to be installed. If they are not compatible, do not operate the equipment and contact a CIRCOR representative before proceeding.

Installation

Pre-installation

Precautions



WARNING:



When installing in a potentially explosive environment ensure that the motor is properly certified



All equipment being installed must be properly grounded to prevent unexpected discharge. Discharge causes equipment damage, electric shock and can result in serious injury. Test the ground lead to verify it is connected correctly.



NOTICE:

Electrical connections must be made by certified electricians in compliance with all international, national, state and local regulations

Supervision by an authorized CIRCOR representative is recommended to ensure proper installation. Improper installation may result in equipment damage or decreased performance

Pump location guidelines

Guideline	Explanation/comment
Locating the pump as near to the source of fluid supply as possible is advisable	This minimizes the friction loss and keeps the suction piping as short as possible.
The location should be well lit and dry with enough room to perform routine maintenance	This facilitates ventilation, inspection, maintenance, and service.
Ensured space enough for rigging, lifting equipment etc. such as a crane, hoist or tackle..	This makes it easier to properly use the lifting equipment and safely remove and relocate the components to a safe location.
Protect the unit from weather and water damage due to rain, flooding, and freezing temperatures.	If you find it necessary to locate the unit in a pit, be sure to make provisions to prevent flooding.
Do not install and operate the equipment in closed systems unless the pump or system is constructed with properly-sized safety devices and control devices.	Acceptable devices: <ul style="list-style-type: none"> • Pressure relief valves (integral to the pump or system mounted) • Pressure controls • Temperature controls • Flow controls If the system does not include these devices, consult with the engineer in-charge before you operate the pump.
Take into consideration the occurrence of unwanted noise and vibration.	The best pump location for noise and vibration absorption is on a concrete floor with correctly compacted and mechanically stabilized subsoil underneath.
If the pump location is overhead, undertake special precautions to reduce possible noise transmission.	Consider a consultation with a noise specialist.

Foundation requirements

Requirements

Foundations should be of suitable mass to absorb vibration and provide a rigid support for the unit. Use reinforcing steel as necessary. For optimal vibration performance, the foundation should weigh between two and three times the weight of the pump.

A flat, substantial concrete foundation is necessary in order to prevent strain and distortion when you tighten the foundation bolts. A template should be made to position and hold the foundation bolts in place while pouring the concrete. Location and sizes of bolt holes are shown on the certified outline drawing supplied to the purchaser. Each bolt is installed in a pipe sleeve. The pipe sleeve allows for minor adjustments in bolt spacing after foundation is in place (Fig. 3a and 3b).

Three methods commonly used to secure and prevent bolts from turning are:

- A washer is placed between the bolt head and pipe sleeve with a lug welded to the bolt head (Figure 3a).
- An opening in the foundation to allow the lower bolt head to be held with a tool (Figure 3b).
- A bolt of rod construction with a bend (sometimes called a “J” or “L” bolt). These are not preferred as they tend to create localized high stresses in the concrete.

The length of the pipe sleeve (and the free length of the bolt that is not encased in concrete) should be the greater of 12X the bolt diameter or 150mm (6 in)

The inside diameter of the pipe sleeve should be two times the outside diameter of the bolt. Provision of a 3-part foundation bolt with a coupling and above foundation notch will allow easier replacement of any foundation bolt that fails due to over tightening or other issue. Foundation bolts must be long enough to allow for at least 25mm (1in) for grouting under the base plate (See the figure below). When pump is level, the bolts should extend 6mm (0.25in) through the nuts. Leave top surface of foundations rough for adherence of grout.

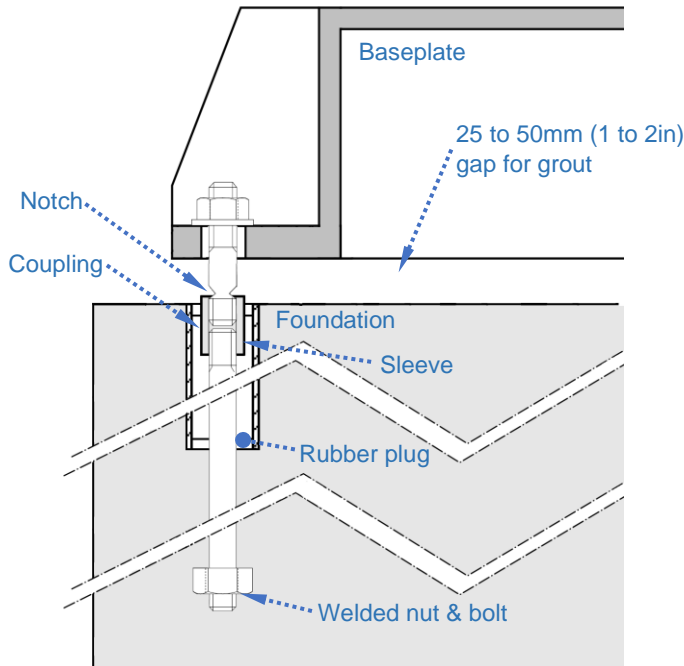

Figure 3a: Sleeve type bolt (embedded)

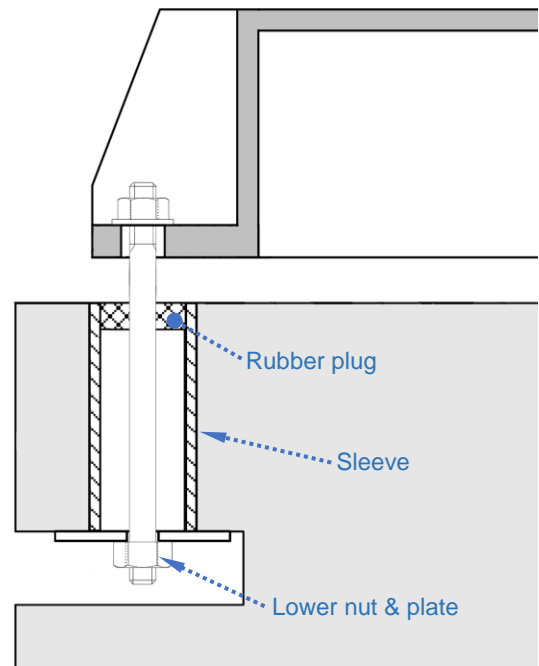

Figure 3b: Sleeve type bolt (pocket)

Baseplate-mounting procedures

Prepare the baseplate for mounting

This procedure assumes you have a basic knowledge of baseplate and foundation design and installation methods. Follow industry-standard procedures, such as API RP 686 together with this procedure before you grout the baseplate.

Make sure that all baseplate surfaces that will contact grout are free from contamination such as debris, paint or preservative. Thoroughly clean all baseplate surfaces that will come into contact with the grout. Be sure to use a cleaner that will not leave any residue.



NOTICE:

You may need to sandblast the surfaces of a baseplate that come into contact with the grout, and then coat those surfaces with a primer that is grout-compatible. Refer to the grout manufacturer's instructions for guidance. Remove all equipment from the baseplate prior to sandblasting.



NOTICE:

Remove all dirt, paint, preservative and debris from the mounting pads in order to ensure that the correct leveling is achieved. Failure to do so can result in equipment damage or decreased performance.

Make sure that all machined surfaces are free from raised edges, burrs, rust, paint, or any other type of contamination. If necessary, use a file or grinding wheel to remove raised edges or burrs.

Prepare the foundation for mounting

Chip the top of the foundation to achieve a minimum of 25mm (1in) gap with the bottom of the baseplate, in order to remove any porous, cracked or low-strength concrete. If you use a pneumatic chisel or other air powered tool, make sure that it does not contaminate the surface with oil or moisture.



NOTICE:

Do not chip the foundation using heavy power tools such as jackhammers. This can damage the structural integrity of the foundation.

1. Remove any water or accumulated debris from the foundation bolt holes or sleeves using an industrial vacuum.
2. If the baseplate uses sleeve-type bolts (recommended), it is important in order to seal the void and to prevent grout or water from entering. Fill the gap between the sleeve and the bolt with a flexible material such as RTV silicone or a rubber plug designed for the purpose.
3. Coat the exposed portion of the anchor bolts with paste wax in order to prevent the grout from adhering to the anchor bolts. Do not use oils or liquid wax.
4. If recommended by the grout manufacturer instructions, coat the foundation surface with a compatible primer.

Install the baseplate

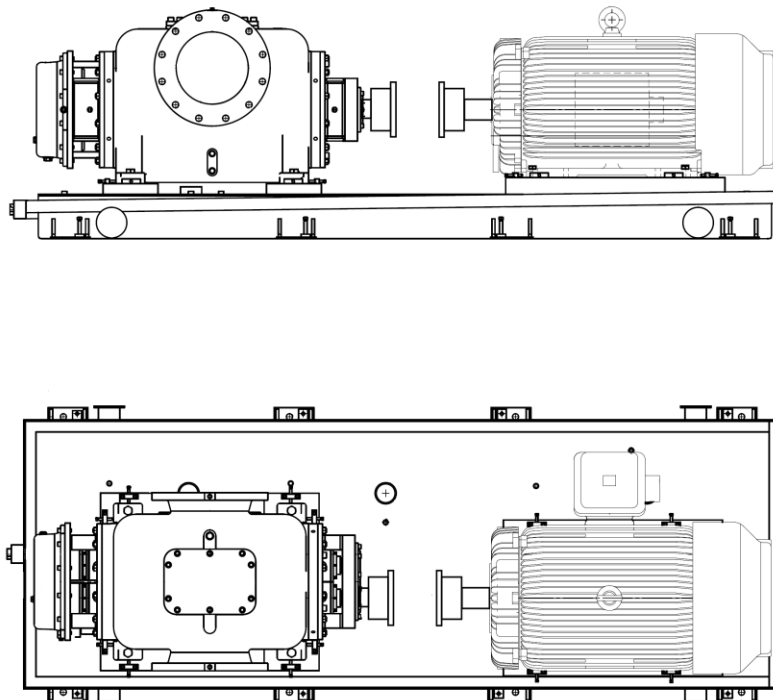

Figure 4: Install the baseplate

1. Lower the baseplate carefully onto the foundation bolts.
2. The baseplate will rest on top of the foundation on the jackscrews provided on the baseplate.
3. Adjust the leveling jackscrews, located adjacent to the foundation bolt holes, until the baseplate rests 25 to 50mm (1 to 2in) above the foundation in order to allow adequate space for grouting.
4. Level the baseplate machined equipment mounting pads to within 0.167mm/m (0.002" per ft) of the length and width of the baseplate by adjusting the jackscrews. Use a precision machinist's level with a graduation sensitivity of 0.0025mm per 250mm (0.0001in per 10in), or an equivalent laser system for this task. The maximum allowable total variation from end to end or side to side of the baseplate, regardless of baseplate size, is 0.38mm (0.015in).
5. Wrap the portion of the jackscrew exposed below the baseplate with electrical tape and then coat with paste wax. This facilitates removal of the jacking screws after grouting.
6. Do not use oils or liquid wax.
7. Install washers and then thread the nuts onto the foundation bolts and hand-tighten.

**WARNING:**

It is to be noted that conventional baseplates have to be installed and grouted on foundation with pump and motor removed. Only then should pump and motor shall be installed and aligned.

Install the pump, driver, and coupling

1. If the pump is not already on the baseplate, mount and fasten the pump on the baseplate using the fasteners provided.
2. If the driver is not already on the baseplate, mount and fasten the pump on the baseplate using the fasteners provided. Hand tighten the fasteners.
3. Install the coupling. See the installation instructions from the coupling manufacturer.

Pump-to-driver alignment

Precautions

**WARNING:**

Failure to disconnect and lock out driver power may result in serious physical injury or death. Always disconnect and lock out power to the driver before performing any installation or maintenance tasks.

Refer to driver/coupling/gear manufacturer's installation and operation manuals (IOM) for specific safety instructions, requirements and recommendations.

Alignment methods

There are three common alignment methods that can be used:

- Dial indicator
- Reverse dial indicator
- Laser

Follow the instructions from the equipment manufacturer when you use the reverse dial indicator or laser methods. Detailed instructions for using the dial indicator method are contained in this chapter.

Alignment checks

When to perform alignment checks

You must perform alignment checks under these circumstances:

- The process temperature changes (as this will affect the thermal growth of the pump).
- The piping connected to the pump is removed and reinstalled or replaced.
- The pump has been serviced and/or disassembled (partially or fully).

Types of alignment checks

Type of check	When it is to be used
Initial alignment (cold alignment) check	Prior to operation when the pump and the driver are at ambient temperature.
Final alignment (hot alignment) check	After operation when the pump and the driver are at operating temperature.

Initial alignment (cold alignment) checks

When	Why
Before you grout the baseplate	This ensures that alignment can be accomplished later.
After you grout the baseplate	This ensures that no changes have occurred during the grouting and foundation bolt tightening process.
After you connect the piping	This ensures that pipe strain has not altered the alignment. If changes have occurred, you must revise the piping arrangement and/or piping supports to remove pipe strains on the pump flanges.

Final alignment (hot alignment) checks

When	Why
After the first run	This ensures that no unexpected movement of the pump or driver has occurred.
Periodically	Follow the plant operating procedures for periodic checks.

Allowable dial indicator values for alignment checks



NOTICE:

The specified misalignment values are valid only at operating temperature. For cold settings, different values must be used to account for the expected thermal expansion. Failure to do so can result in being unable to successfully perform hot alignment.

The driver shaft initial (cold) parallel vertical alignment setting should normally be lower than the pump shaft (unless the pump operates at a high process temperature, see the next section). Follow the driver manufacturer's recommendations.

When dial indicators are used to check the final alignment, the pump and drive unit are correctly aligned when the conditions shown below are established:

Pump running speed	Indicator maximum allowable Total Indicated Reading (TIR) @ operating temperature
3600 RPM	0.05mm (0.002in)
1800 RPM	0.1mm (0.004in)
1200 RPM	0.15mm (0.006in)
0 to 900 RPM	0.2mm (0.008in)

Calculate the thermal expansion

Thermal expansion of the driver always has to be considered as drivers are foot mounted. Additionally in cases where the operating temperature of the pump varies considerably from ambient, the amount of thermal expansion in the pump/driver combination becomes important for proper alignment of the coupling.

The following explanations and worked example illustrate the simplicity of these calculations and the necessity that they be made.

The formula for thermal expansion is expressed as:

$$\text{Thermal movement} = \alpha \times \Delta t \times (\text{machine foot to shaft centerline distance})$$

The coefficient of expansion α is specific to the material of construction expressed as a value per degree temperature of rise.

The Houttuin 216 series pump may be supplied in the following materials of construction:

Generic Material	Coefficient of thermal expansion α mm/mm/°C (in/in/°F)
Grey Cast Iron	10.8×10^{-6} (6.0×10^{-6})

Ductile Iron	11.7×10^{-6} (6.5×10^{-6})
Carbon Steel	11.7×10^{-6} (6.5×10^{-6})
Austenitic Stainless Steel	16×10^{-6} (8.9×10^{-6})

Temperature rise Δt = operating temperature – ambient temperature. The foot to shaft centerline distance is the distance from the bottom of the pump and driver feet to the center of their respective shafts. This information may be found on the GA or outline drawing.

Worked Example (US units)

Ambient Temperature -	80 °F
Operating Temperature -	224 °F (driver, taken from the max. temperature for Class B)
Operating Temperature -	100 °F (pump)
Material of Construction -	Cast Austenitic Stainless Steel (pump)
Material of Construction -	Cast Steel (driver)
CL Height Pump -	13"
CL Height Driver -	11"

- Change at pump shaft due to temperature rise = $8.9 \times 10^{-6} \times (100-80) \times 13" = 0.002"$
- Change at driver shaft due to temperature rise = $6.5 \times 10^{-6} \times (224-80) \times 11" = 0.010"$
- Difference = $0.002" - 0.010" = -0.008"$

In this example, the pump should be set 0.008" higher than the driver to allow for proper alignment at operating temperatures.

The above formula is an approximation and does not account for the influences of piping, casing geometry and hot and cold spots created by circulation of air. Hence while it is important to utilize the above method for cold alignment, final alignment should still be checked in the hot condition.

The following steps should be taken to ensure proper coupling alignment during operation.

1. Calculate thermal growth and compensate accordingly when aligning the coupling.
2. Check coupling alignment while both pump and driver are hot to ensure alignment is correct for the operating conditions.

Alignment measurement guidelines

Guideline	Explanation
Rotate the pump coupling half and the driver coupling half together so that the indicator rods have contact with the same points on the driver coupling half.	This prevents an incorrect measurement.
Move or shim only the driver in order to make adjustments.	This prevents strain on the piping installations.
Make sure that the hold-down bolts for the driver feet are tight when you take indicator measurements.	This keeps the driver stationary since movement will cause an incorrect measurement.
Make sure that the hold-down bolts for the driver feet are loose before you make alignment corrections.	This makes it possible to move the driver when you make alignment corrections.
Check the alignment again after any mechanical adjustments.	This corrects any misalignments that an adjustment may have caused.

Attach the dial indicators for alignment

You must have two dial indicators in order to complete this procedure.

Attach two dial indicators on the pump coupling half

Attach one indicator so that the indicator tip contacts the perimeter of the driver coupling half.

This indicator is used to measure parallel misalignment.

Attach the other indicator so that the indicator tip contacts the end face of the driver coupling half. This indicator is used to measure angular misalignment.

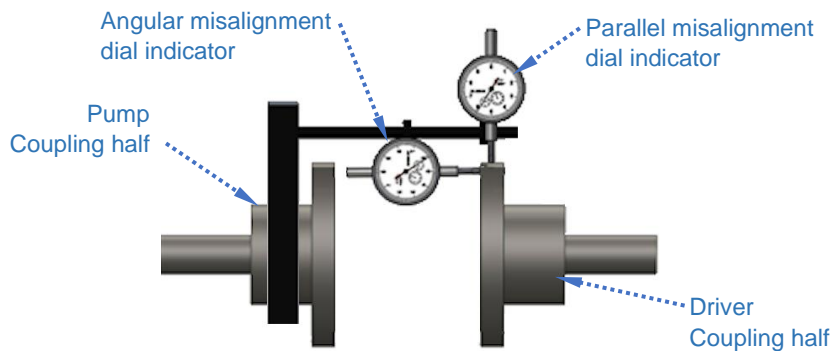

Figure 5 Dial indicator attachment

1. Rotate the pump coupling half in order to check that the indicators are in contact with the driver coupling half and do not bottom out at any point during the rotation.
2. Adjust the indicators if necessary.

Perform angular alignment for a vertical correction

1. Set the angular alignment indicator to zero at the top-center position (12 o'clock) of the driver coupling half.
2. Rotate the angular alignment indicator to the bottom-center position (6 o'clock).
3. Record the angular alignment indicator reading.
4. Repeat the previous steps until the allowable reading value is achieved.

When the reading value is...	Then do this.
Negative	The coupling halves are farther apart at the bottom than at the top. To correct this do one of the following: <ul style="list-style-type: none"> • Add shims in order to raise the feet of the driver at the DE. • Remove shims in order to lower the feet of the driver at the NDE.
Positive	The coupling halves are closer at the bottom than at the top. To correct this do one of the following: <ul style="list-style-type: none"> • Remove shims in order to lower the feet of the driver at the DE. • Add shims in order to raise the feet of the driver at the NDE.

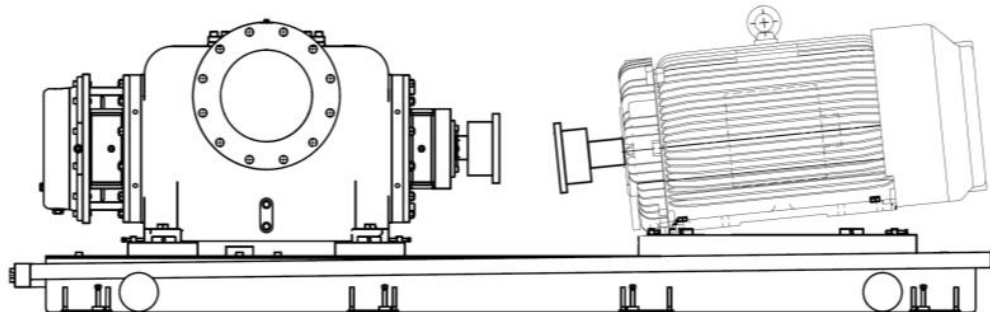

Figure 6 Example of incorrect vertical alignment (side view)

Perform angular alignment for a horizontal correction

1. Set the angular alignment indicator to zero on left side of the driver coupling half, 90° from the top-center position (9 o'clock).
2. Rotate the angular alignment indicator through the top-center position to the right side, 180° from the start position (3 o'clock).
3. Record the indicator reading.
4. Repeat the previous steps until the allowable reading value is achieved.

When the reading value is...	Then do this.
Negative	The coupling halves are farther apart on the right side than the left. To correct this, do one of the following: <ul style="list-style-type: none"> • Slide the DE of the driver to the left. • Slide the NDE of the driver to the right.
Positive	The coupling halves are closer together on the right side than the left. To correct this do one of the following: <ul style="list-style-type: none"> • Slide the DE of the driver to the right. • Slide the NDE of the driver to the left.

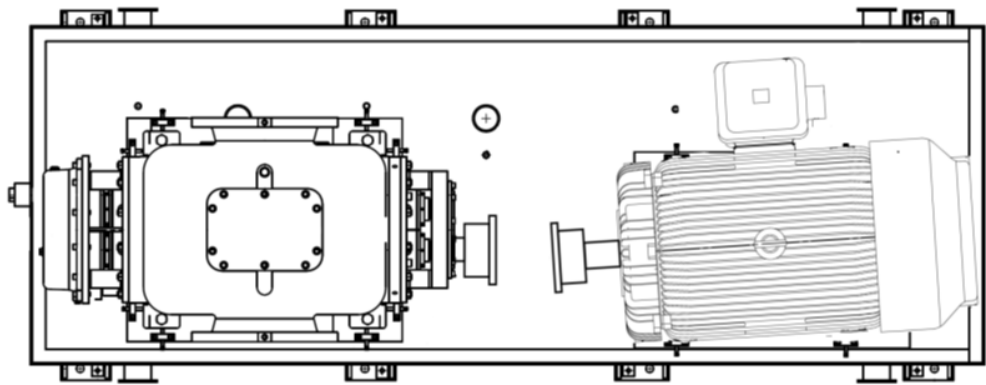

Figure 7 Example of incorrect horizontal alignment (top view)

Perform parallel alignment for a vertical correction

Refer to the "**Calculate the thermal expansion**" section for the proper cold alignment value based on the driver temperature rise and the pump operating temperature. Before you start this procedure, make sure that the dial indicators are correctly set up. A unit is in parallel alignment when the parallel alignment indicator does not vary by more than the table limits when measured at four points 90° apart at the operating temperature.



NOTICE:

The specified misalignment values are valid only at operating temperature. For cold settings, different values must be used to account for the expected thermal expansion. Failure to do so can result in being unable to successfully perform hot alignment.

1. Set the parallel alignment indicator to zero at the top-center position (12 o'clock) of the driver coupling half.
2. Rotate the indicator to the bottom-center position (6 o'clock).
3. Record the indicator reading.
4. Add or remove shims in equal amounts from under all driver feet.
5. Repeat the previous steps until the allowable reading value is achieved.

When the reading value is...	Then do this
Negative	The pump coupling half is lower than the driver coupling half. Remove shim(s) with a thickness equal to half of the indicator reading value under each driver foot.
Positive	The pump coupling half is higher than the driver coupling half. Add shim(s) with a thickness equal to half of the indicator reading value to each driver foot.

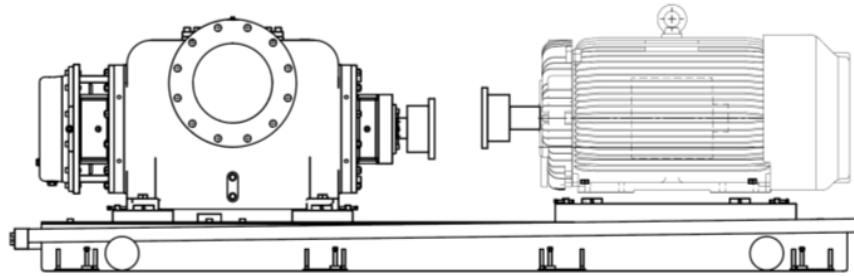

Figure 8 Example of incorrect vertical alignment (side view)

Perform parallel alignment for a horizontal correction

Refer to the table in "**Allowable indicator values for alignment checks**" for the proper alignment values.

A unit is in parallel alignment when the parallel alignment indicator does not vary by more than the table limits when measured at four points 90° apart at the operating temperature.

1. Set the parallel alignment indicator to zero on the left side of the driver coupling half, 90° from the top-center position (9 o'clock).
2. Rotate the indicator through the top-center position to the right side, 180° from the start position (3 o'clock).
3. Record the indicator reading.

When the reading value is...	Then...
Negative	The driver coupling half (Y) is to the left of the pump coupling half (X).
Positive	The driver coupling half (Y) is to the right of the pump coupling half (X).

4. Slide the driver carefully in the appropriate direction.
5. Repeat the previous steps until the allowable reading value is achieved



NOTICE:

Make sure to move the driver evenly. (If available, using the horizontal jacking posts and applying equal turns to each jacking screw is an effective way to do this.) Failure to do so will

negatively affect horizontal angular correction and may require re-performing the angular alignment step.

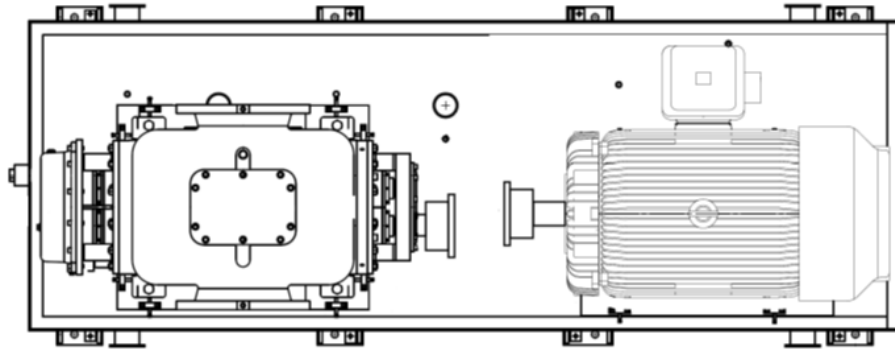

Figure 9 Example of incorrect horizontal alignment (top view)

Perform complete alignment for a vertical correction

Refer to "**Allowable indicator values for alignment checks**" for the alignment values.

A unit is in complete alignment when both the angular alignment indicator and the parallel alignment indicator do not vary by more than the table limits when measured at two points 180° apart at the operating temperature.



NOTICE:

The specified misalignment values are valid only at operating temperature. For cold settings, different values must be used to account for the expected thermal expansion. Failure to do so can result in being unable to successfully perform hot alignment.

1. Set the angular and parallel dial indicators to zero at the top-center position (12 o'clock) of the driver coupling half.
2. Rotate the indicators to the bottom-center position (6 o'clock).
3. Record the indicator readings.
4. Make corrections according to the separate instructions for angular and parallel alignment until you obtain the allowable reading values.

Perform complete alignment for a horizontal correction

A unit is in complete alignment when both the angular alignment indicator and the parallel alignment indicator do not vary by more than the table limits when measured at two points 180° apart at the operating temperature.

1. Set the angular and parallel dial indicators to zero at the left side of the driver coupling half, 90° from the top-center position (9 o'clock).
2. Rotate the indicators through the top-center position to the right side, 180° from the start position (3 o'clock).
3. Record the indicator readings.

4. Make corrections according to the separate instructions for angular and parallel alignment until you obtain the allowable reading values.

Grout the baseplate

Required equipment:

- Cleaners: Do not use an oil-based cleaner, the grout will not bond to it. Refer to the instructions provided by the grout manufacturer on suitable cleaners to be used.
- Grout: Non-shrink cementitious grout or epoxy grout is recommended.



NOTICE:

Always use an installation contractor that is experienced in grouting similar types of equipment and can follow the procedures detailed in API RP 686, Chapter 5; and other industry standards. It can't be overstated - the critical importance of a high-quality grout installation in enabling the long-term reliability and performance of the equipment.

1. Clean all the areas of the baseplate that will come into contact with the grout.
2. Build a dam around the foundation. The dam must be high enough to contain the grout pour. It is recommended that the dam height be at least 25mm (1in) higher than the final level of the grout. If epoxy grout is to be used, the dam must include the 45° angle edge chamfer (see also step 9.)
3. If cement type grout is used, thoroughly wet and saturate the foundation that will come into contact with the grout for at least 24 hours prior to grout placement.
4. If epoxy type grout is used, then the foundation must be completely dry.
5. Shade the foundation and equipment from sunlight for 24 hours prior to grout placement to ensure temperature equalization has occurred.
6. Use a properly shaped temporary form on the short side of the foundation to create positive head pressure of 150 to 200mm (6 to 8in) and pour the grout smoothly and without turbulence letting it flow under the baseplate. **Never place grout from both sides of the foundation.**
7. Continue pouring until the grout level just above that of the lower baseplate surface.
8. If correctly mixed and poured, air entrainment in the grout should be absent or minimal. However, if necessary after the grout is poured, remove any remaining air bubbles from it by using a suitable vibratory tool designed specifically for the release of air from grout.
9. The edge of the grout should be chamfered at a 45° angle in order to remove crack prone square edges. The chamfer can be accomplished by building the 45° angle into the dam form. Alternatively, for cement type grouts, the chamfer can be applied after the initial solidification of the grout.
10. Keep the foundation and equipment shaded from the sun for at least 48 hours after pouring to allow the grout to fully set. If a cement type grout is used, wet cure all exposed areas of

grout immediately followed by application of a high solids, film forming curing compound compliant with ASTM C309 or C1325.

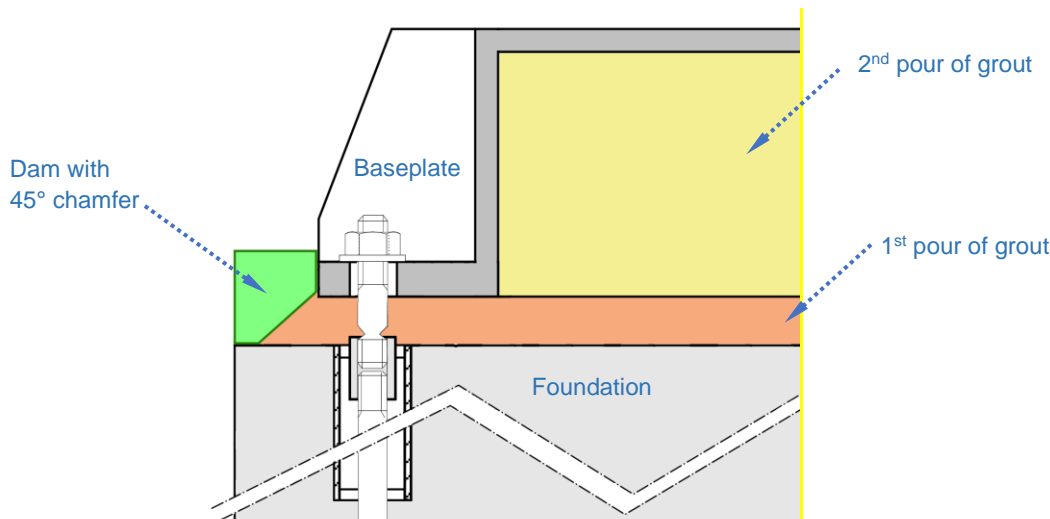

Figure 10: Arrangement of grout pour into baseplate

11. Fill the remainder of the baseplate with grout and allow the grout to set for at least 48 hours.
12. Remove the leveling jackscrews after the grout hardens in order to remove any stress points.
13. Tighten the foundation bolts.
14. Recheck the alignment.

Perform a final “soft foot” check

A final check for soft foot should be made after completion of coupling alignment and grouting. A soft foot condition may result in body stresses that may result in shortened bearing life. Soft foot may be checked as follows:

1. Attach the base of a dial indicator to the base plate, placing the tip of the indicator one of the pump's feet.
2. Adjust the indicator to read zero.
3. Loosen the hold down bolt at the foot on which the indicator is reading.
4. If the indicator shows movement of greater than 0.05mm (0.002in) the foot is said to be “soft”.
5. Shim under the soft foot to reduce the indicator travel to less than 0.05mm (0.002in). If multiple shims are already in place, the use of fewer, thicker shims will reduce the tendency of soft foot to occur.
6. Repeat this process until all of the pump feet have been checked and corrected for a soft foot condition.

If a dial indicator is not available, feeler gauges may be used

Pump Piping

General piping requirements and checklist

Precautions



WARNING:

 Risk of premature pump failure. Casing deformation can result in misalignment and contact with rotating parts, causing excess heat generation and sparks. Flange loads from the piping system, including those from the thermal expansion of the piping, must not exceed the limits of the pump.



CAUTION:

 The pump is not designed to be a pipe anchor. Never draw piping into place at the flanged connections of the pump. This can impose dangerous strains on the unit and misalignment between the pump and driver. Pipe strain adversely affects the operation of the pump, which results in physical injury and damage to the equipment.

Flange loads from the piping system, including those from the thermal expansion of the piping, must not exceed the limits of the pump. Casing deformation can result in contact with rotating parts, which can result in excess heat generation, sparks, and premature failure.



NOTICE:

Never attempt to throttle the flow from either the suction side or discharge side of a PD pump. This action can result in decreased performance, unexpected heat generation, and equipment damage.

Piping guidelines

Guidelines for pump piping are given in the Hydraulic Institute Standards 9.6.6 and 9.8.

These should be referred to when making any system design.

Checklist

Check	Explanation/comment	Checked
All major piping must be supported independently of the pump and properly aligned with pump flanges. See Alignment criteria for pump flanges.	Piping strain on the pump may cause distortion resulting in misalignment or vibration	
Keep the suction and discharge piping as short and direct as possible.	The pump cannot overcome deficiencies in system design such as long runs of suction piping, possibly undersized and containing many elbows, valves, and particularly high points that are above the pump suction. In such cases, the pump runs increased risk of being noisy and with higher vibration.	
Check that only the minimum necessary fittings are used, and the fittings used are a type that minimizes losses.	Long discharge piping runs with many fittings will increase system losses and reduce overall efficiency. Use long radius elbows to change direction wherever possible.	

<p>Do not connect the piping to the pump until:</p> <ul style="list-style-type: none"> • The grout for the baseplate or sub-base becomes hard. • The hold-down bolts for the pump are tightened. 	<p>Connecting the piping without adequate pump support increases the risk of pipe strain</p> <p>Piping strain on the pump may cause distortion resulting in misalignment or vibration</p>	
<p>Check</p>	<p>Explanation/comment</p>	<p>Checked</p>
<p>Piping, subject to high temperatures, must be fitted with a means of absorbing expansion.</p>	<p>Piping strain on the pump (due to thermal expansion), may cause distortion resulting in misalignment or vibration</p>	
<p>Make sure that all piping components, valves and fittings, and pump branches are clean prior to assembly.</p>	<p>Twin-Screw rotors incorporate very close running clearances, it is very important that suction side piping be thoroughly cleaned before connecting piping to the pump to prevent the introduction of small hard damaging particles such as weld spatter or grit</p>	
<p>Make sure that the isolation and check valves are installed in the discharge line.</p>	<p>Locate the check valve between the isolation valve and the pump. This will permit inspection of the check valve. The isolation valve is required for inspection and maintenance of the pump. The check valve will prevent hydraulic shock acting upon the pump and will also prevent reverse rotation of the pump when stopping the unit.</p>	
<p>Fit suitable pressure relief valve to the pump discharge</p>	<p>Pressure relief valves must be installed between the discharge valve and the casing discharge flange of 2-Screw pumps to protect both the pump and piping system. The valve and piping system must be solidly constructed of proper material with ample opening for passage of full discharge capacity, because positive displacement pumps can build up pressure rapidly, if the discharge is restricted or shut off. This type of relief valve must lead back to the source of supply or other suitable collecting point to prevent product loss and an excessive temperature rise of the re-circulated fluid in pump that operate unattended.</p>	

Alignment criteria for pump flanges

To check piping alignment of pumps having bolted flanges, insert flange bolts through pipe and pump flange. If bolts are easily moved within the bolt holes and if flange faces are parallel with each other, piping is properly aligned.

Maintain sufficient gap between flange faces for inserting the gasket. Flanges must not butt tightly before being secured. The criteria below apply to acceptable alignment for the flanges.

Flange position criteria	Acceptable position
Axial	The flange gasket thickness +0.25mm (0.010in), +1mm (0.040in)
Parallel	Align the flange to be parallel within 0.3° 1mm per 200mm (0.063 per 12in).
Concentric	Studs are centered in the holes or the flange bolts can be inserted and moved by hand.

Fastening



WARNING:

Risk of serious personal injury or property damage. Fasteners such as bolts and nuts are critical to the safe and reliable operation of the product. Ensure appropriate use of fasteners during installation or reassembly of the unit.

The fasteners must be the correct size and material. Any fasteners found to be corroded, galled, stripped or otherwise damaged must be replaced. Ensure that all fasteners are properly tightened and that there are no missing fasteners.

Suction-piping checklist

Suction-piping checks

Check	Explanation/comment	Checked
Check that any pipe elbows do not have sharp bends.	Use long radius elbows to change direction wherever possible.	
Check that the suction piping is one or two sizes larger than the suction inlet of the pump. Install an eccentric reducer between the pump inlet and the suction piping. (For vertical suction a concentric reducer can be used).	The suction piping should never have a smaller diameter than the suction inlet of the pump. This minimizes the pipework friction losses leading up to the pump.	
Check that the eccentric reducer at the suction flange of the pump has the following properties: <ul style="list-style-type: none"> • Sloping side down • Horizontal side at the top 	Not applicable for pumps with a vertical suction arrangement	
Check	Explanation/comment	Checked
It is recommended that a commissioning (temporary) suction strainer be used. After commissioning it is recommended an operating (permanent) suction strainer be used. Check that the strainer has at least five times the area of the suction piping. Some applications with very high viscosities may not be able to successfully utilize a suction strainer due to the losses these introduce. If in doubt consult with the system designer.	Suction strainers help to prevent debris from entering the pump Recommended commissioning (temporary) strainer mesh size: <ul style="list-style-type: none"> • Viscosity<=86cSt (450 SSU) use 60 mesh • Viscosity>86cSt (450 SSU) use 40 mesh • Viscosity>216cSt (1000 SSU) use 20 mesh Continuously monitor the pressure drop across the suction strainer. Limit the pressure drop across the strainer to the lesser of 0.7bar (10 psi), or the vapor pressure of the pumped fluid. System flushing is complete when the strainer pressure drop stabilizes, and periodic inspection of the strainer confirms that any accumulation of debris has stopped. At this point	

	<p>the commissioning (temporary) suction strainer can be removed.</p> <p>Recommended operating (permanent) strainer mesh size:</p> <ul style="list-style-type: none"> • Viscosity ≤ 86cSt (450 SSU) use 40 mesh • Viscosity > 86cSt (450 SSU) use 20 mesh • Viscosity > 216cSt (1000 SSU) use 12 mesh 	
If more than one pump operates from the same liquid source, check that separate suction-piping lines are used for each pump.	This recommendation helps you to achieve a higher pump performance and prevent vapor locking especially with light volatile fluids	
If necessary, make sure that the suction piping includes a drain valve and that it is correctly installed.		
Assure adequate insulation is applied for liquids with specific gravity less than 0.7.	Low specific gravity fluids typically have high vapor pressures and are sensitive to thermal gain from the heat flow through uninsulated piping. To assure sufficient NPSHa in these applications, insulation is strongly recommended.	

Liquid source below the pump

Check	Explanation/comment	Checked
Make sure that the suction piping is free from air pockets.	This helps to prevent the occurrence of air and cavitation in the pump inlet.	
Check that the suction piping slopes upwards from the liquid source to the pump inlet.	This helps to eliminate any air from the pipework	
Check that all joints are air-tight.	Air leaks increase the effective NPSHr of the pump	
Check that a device for priming the pump is installed – such as a foot valve is installed.	Use a foot valve with a diameter that is at least equivalent to the diameter of the suction piping. Foot valves are not usually required when handling liquids of higher viscosity	

Liquid source above the pump

Check	Explanation/comment	Checked
Check that an isolation valve is installed in the suction piping.	This allows closure of the suction line during pump inspection and maintenance.	
Make sure that the suction piping is free from air pockets.	This helps to prevent the occurrence of air and cavitation in the pump inlet.	
Check that the piping is level or slopes downward from the liquid source.	This helps to eliminate any air from the pipework	
Make sure that no part of the suction piping extends below the suction flange of the pump.	This helps to eliminate the possibility of trapped air pockets forming in the pipework	
Make sure that the suction piping is adequately submerged below the surface of the liquid source.	This prevents air from entering the pump through a suction vortex.	

Discharge piping checklist

Checklist

Check	Explanation/comment	Checked
Check that an isolation valve is installed in the discharge line	The isolation valve is required for inspection and maintenance of the pump	
Check that a check valve is installed in the discharge line, between the isolation valve and the pump discharge outlet.	The location between the isolation valve and the pump allows inspection of the check valve. The check valve will prevent hydraulic shock acting upon the pump and will also prevent reverse rotation of the pump when stopping the unit.	
Check that a vent valve is installed in the discharge piping prior to the check valve.	This is only mandatory if pump operates with a suction lift.	
Fit suitable pressure relief valve to the pump discharge	Pressure relief valves must be installed between the discharge valve and the casing discharge flange of 2-Screw pumps to protect both the pump and piping system. The valve and piping system must be solidly constructed of proper material with ample opening for passage of full discharge capacity, because positive displacement pumps can build up pressure rapidly, if the discharge is restricted or shut off. This type of relief valve must lead back to the source of supply or other suitable collecting point to prevent product loss and an excessive temperature rise of the re-circulated fluid in pump that operate unattended.	

Auxiliary-piping checklist

Precautions



CAUTION:

Risk of significant heat generation, seal failure, and possible physical injury. Sealing systems that are not self-purging or self-venting require manual venting prior to operation. Read the seal system supplier's instructions to confirm venting requirements.

Running a mechanical seal dry, even momentarily, can cause seal failure and physical injury. Never operate the pump without confirming that liquid is supplied to the mechanical seal.

Auxiliary cooling and flush systems must be operating properly to prevent excess heat generation, sparks, and/or premature failure.



NOTICE:

Ensure auxiliary piping is installed as specified on the pump data sheet prior to startup.

When to install

You may need to install auxiliary piping for gear / bearing cooling, mechanical seal flush, or other special features supplied with the pump. Consult the pump GA or outline drawing for specific auxiliary piping requirements and connection points.

Checklist

Check	Explanation/comment	Checked
Check that the minimum flow for each component meets or exceeds the GA / outline drawing value	–	
Check that the supplied pressure does not exceed the GA / outline drawing maximum allowable value	–	

Final piping checklist

Check	Explanation/comment	Checked
Check that the shaft rotates smoothly.	Rotate the shaft by hand. Make sure there is no binding or rubbing that can potentially lead to excess heat generation or sparks.	
Re-check the alignment to make sure that pipe strain has not caused any misalignment.	If pipe strain exists, then correct the piping arrangement.	

Commissioning, Startup, Operation & Shutdown

Preparation for startup

**WARNING:**

- Risk of serious physical injury or death. Exceeding any of the pump operating limits (e.g. pressure, temperature, power, etc.) could result in equipment failure, such as explosion, seizure, or breach of containment. Assure that the system operating conditions are within the capabilities of the pump.
- Risk of death or serious injury. Leaking fluid can cause fire and/or burns. Ensure all openings are sealed prior to filling the pump.
- Breach of containment can cause fire, burns, and other serious injury. Failure to follow these precautions before starting the unit may lead to dangerous operating conditions, equipment failure, and breach of containment.
- Risk of explosion and serious physical injury. Do not operate pump with blocked system piping or with suction or discharge valves closed. This can result in rapid heating and vaporization of pumped fluid.
- Risk of breach of containment and equipment damage. Ensure the pump operates only between minimum and maximum rated flows. Operation outside of these limits can cause high vibration, mechanical seal and/or shaft failure, and/or loss of prime.

**WARNING:**

- Running a pump without safety devices exposes operators to risk of serious personal injury or death. Never operate a unit unless appropriate safety devices (guards, etc.) are properly installed.
- Failure to disconnect and lock out driver power may result in serious physical injury or death. Always disconnect and lock out power to the driver before performing any installation or maintenance tasks.
- Electrical connections must be made by certified electricians in compliance with all international, national, state, and local rules.
- Refer to driver/coupling/gear manufacturer's installation and operation manuals (IOM) for specific instructions and recommendations.
- Do not change the relief valve settings this can cause serious damage on the pump.

Precautions

**NOTICE:**

- Verify the VFD and driver connections and settings before you start the pump.
- Excessive warm-up rates can cause equipment damage. Ensure the warm-up rate does not exceed 2.2°C (4°F) per minute.
- The maximum allowable temperature change for an abnormal transient event such as thermal shock is 83°C (150°F).

- When a cartridge mechanical seal is used, ensure that the set screws in the seal locking ring are tightened and that the centering clips have been removed prior to startup. This prevents seal or shaft sleeve damage by ensuring that the seal is properly installed and centered on the sleeve.

You must follow these precautions before you start the pump:

- Flush and clean the system thoroughly to remove dirt or debris in the pipe system in order to prevent premature failure at initial startup.
- If temperatures of the pumped fluid will exceed 107°C (225°F), then warm up the pump prior to operation. Circulate a small amount of fluid through the pump until the casing temperature is within 28°C (50°F) of the fluid temperature. Accomplish this by flowing fluid at 0.23m³/h (1 GPM) or 0.25% of the pump rated flow, whichever is larger, into the pump casing drain and out of the discharge nozzle (optionally, the casing vent can be included in warm-up circuit).
- The recommended warm up rate is 1.1°C to 2.2°C (2°F to 4°F) per minute. During the warm up process confirm the temperature differential between the top and bottom of the pump is less than 17°C (30°F). Allow the pump to stabilize for 2 hours at the process fluid temperature.

Check the rotation



WARNING:

Starting the pump in reverse rotation can result in the contact of metal parts, heat generation, and breach of containment. Ensure correct driver settings prior to starting any pump.

Failure to disconnect and lock out driver power may result in serious physical injury or death. Always disconnect and lock out power to the driver before performing any installation or maintenance tasks.

Electrical connections must be made by certified electricians in compliance with all international, national, state, and local rules.

Refer to driver/coupling/gear manufacturer's installation and operation manuals (IOM) for specific instructions and recommendations.

1. Lock out power to the driver.
2. Remove the coupling guard
3. Make sure that the coupling hubs are fastened securely to the shafts.
4. Make sure that the coupling spacer is removed.
5. The pump is normally shipped with the coupling spacer removed.

6. Unlock power to the driver.
7. Make sure that everyone is clear, and then jog the driver long enough to determine that the direction of rotation corresponds to the arrow on the bearing housing or close-coupled frame.
8. Lock out power to the driver.

Couple the pump and driver



WARNING:

Failure to disconnect and lock out driver power may result in serious physical injury or death. Always disconnect and lock out power to the driver before performing any installation or maintenance tasks.

Electrical connections must be made by certified electricians in compliance with all international, national, state, and local rules.

Refer to driver/coupling/gear manufacturer's installation and operation manuals (IOM) for specific instructions and recommendations.

1. Check the gap between the coupling hubs against the dimensions shown on the general arrangement drawing or as stamped on the coupling hub. For any necessary adjustment, move the driver not the pump.
2. Motors with sleeve bearings may be manufactured with end movement (float) in the motor rotor. If specific directions for setting the motor rotor position are not indicated in the motor instructions, then follow this procedure:
 - a. Slide the motor rotor towards the DE of the motor as far as it will go and mark the shaft at the motor frame.
 - b. Slide the motor rotor towards the NDE of the motor as far as it will go and mark the shaft again.
 - c. Scribe a third mark on the shaft halfway between the scribe marks made in the previous steps.
 - d. Adjust the driver position and/or coupling to ensure the motor rotor will be held in that mid position when the coupling is installed.
3. Use the instructions provided from the coupling manufacturer to install the coupling.
4. Check the angular and parallel alignment of the coupling halves. See Pump-to-driver alignment in the Installation chapter.
5. Install the coupling guard.



WARNING:



The coupling guard used in an ATEX classified environment must be constructed from a

spark resistant material

- Running a pump without safety devices exposes operators to risk of serious personal injury or death. Never operate a unit unless appropriate safety devices (guards, etc.) are properly installed.
- Avoid death or serious injury. Assure mechanical seal guard is properly installed using supplied fastening hardware.
- Failure to disconnect and lock out driver power may result in serious physical injury or death. Always disconnect and lock out power to the driver before performing any installation or maintenance tasks.
- Electrical connections must be made by certified electricians in compliance with all international, national, state, and local rules.
- Refer to driver/coupling/gear manufacturer's installation and operation manuals (IOM) for specific instructions and recommendations.

Bearing lubrication (216.40 pumps only)

Precautions



WARNING:

 Risk of explosive hazard and premature failure from sparks and heat generation. Ensure That the bearings are properly lubricated prior to startup.

Pumps are shipped without oil

You must lubricate the gears and bearings at the job site. The gear and bearing housings are supplied with sight glasses. Make sure that the oil level is set to the center of the sight glass when the pump is not running. (A false level reading can occur while the pump is running).

Oil volume requirements (216.40 pumps only)

Pump Size	Non Drive End Grease Volume (Greased for Life)		Drive End Housing Oil Volume	
	liter	Ounces	liter	gallons
088 & 105	N/A	N/A	1.5	0.4
118 & 135	N/A	N/A	2.5	0.7
150 & 165	N/A	N/A	4.0	1.1
180 & 195	N/A	N/A	6.0	1.6
210 & 225	N/A	N/A	8.5	2.2

Lubricating-oil requirements (216.40 pumps only)

Oil quality requirements

Use a **high-grade synthetic gear oil** with anti-foaming agents; oxidation and corrosion inhibitors. It is suggested that the oils conform approximately to the following characteristics.

Maximum pumped fluid temperature	100°C (212°F)
Bearing Alarm temperature	100°C (212°F)
Bearing Shutdown temperature	110°C (230°F)
ISO Synthetic Grade	VG100
Viscosity, kinematic @ 40°C (104°F)	95 - 105 cSt
Viscosity, kinematic @ 100°C (212°F)	13 cSt
Viscosity Index, Min	140
Flash point, Min	220 °C (428°F)

Acceptable lubricants

Replacement Oil must be the same as, or equivalent to the above.

Grease quality requirements

N/A – Greased for Life is utilized for grease lubricated bearings

Lubricate the bearings with oil (216.40 pumps only)



WARNING:



Risk of explosive hazard and premature failure from sparks and heat generation. Ensure That the bearings are properly lubricated prior to startup.

Remove the filler plug in the top of each housing. Refer to the GA or outline drawing for location.

Fill each housing using a funnel.

Reinstall the filler plug and tighten.

Check that the oil level is correct. The correct oil level is at the center of the sight glass, when the pump is stopped. During operation the sight glass gives a false oil level reading.

Lubricate the gear/bearings after a shutdown period (216.40 pumps only)

1. Fill each housing with the proper lubricating oil after cleaning.

Shaft sealing with a mechanical seal

Precautions

**WARNING:**

The mechanical seal used in an EX- classified environment must be properly certified for the conditions of service.

**CAUTION:**

Running a mechanical seal dry even momentarily can cause seal failure and physical injury. Never operate the pump without a reliable supply of liquid to the mechanical seal. The mechanical seal must have an appropriate seal-flush system. Failure to do so will result in excess heat generation and seal failure.

Cooling systems such as those for bearing lubrication and mechanical-seal systems must be operating properly to prevent excess heat generation, sparks, and premature failure

Sealing systems that are not self-purging or self-venting, such as plan 23₇ require manual venting prior to operation. Failure to do so will result in excess heat generation and seal failure. Follow seal manufacturer's guidelines for proper seal installation procedures.

Seal lubrication is required

Seal faces must have liquid film between them for proper lubrication. If customer supplied sources of liquid must be supplied to the mechanical seal, the pump GA or outline drawings will identify the connections that need to be made and the type/quantity of liquid that must be supplied.

How to prime the pump with the suction supply above the pump

1. Slowly open the suction isolation valve.
2. Open the air vents on the suction and discharge piping, the casing, the seal chamber, and the seal piping, until all air is vented and only the pumped fluid flows out. Note that the air vents provided varies with the configuration of the product. Refer to the pump GA or outline drawing for specific vent locations.
3. Close the air vents.

Start the pump

**WARNING:**

Risk of equipment damage, seal failure and breach of containment. Ensure all flush and cooling systems are operating correctly prior to starting pump.

**NOTICE:**

1. Risk of equipment damage due to dry operation. Immediately observe the pressure gauges. If discharge pressure is not quickly attained, stop the driver immediately, reprime, and attempt to restart the pump.
2. To avoid risk of equipment damage, observe the pump for vibration levels, bearing temperature, and excessive noise. If normal levels are exceeded, shut down the pump and resolve the issue.

On frame mounted units, ensure that the oil level is correct prior to starting pump. Close coupled pumps do not have oil lubricated bearings.

Risk of equipment damage on pure or purge-oil mist-lubricated units. Remove the viewing port plugs to verify that oil mist is flowing properly. Reinstall the plugs after confirming

1. Start the driver.
2. Immediately check the pressure gauge to ensure that the pump discharge pressure is below the maximum design pressure stated on the nameplate.
3. If the pump exceeds the maximum design pressure, perform these steps
 - a. Stop the driver.
 - b. Determine the source of restriction in the discharge piping and remove it.
 - c. Restart the driver.
4. If the pump fails to produce flow, perform these steps:
 - a. Stop the driver.
 - b. Prime the pump again.
 - c. Restart the driver.
5. Monitor the pump while it is operating:
6. Check the pump for bearing temperature, excessive vibration, and noise.
7. If the pump exceeds normal levels, then shut down the pump immediately and correct the problem. A pump can exceed normal levels for many reasons. Refer to the Troubleshooting section for information about possible solutions.
8. Repeat steps 1 through 4 until the pump runs properly.

Pump operation precautions

General considerations

Check the unit for unusual noise or vibration. Any unusual vibration or change in sound must be investigated as it may be the first sign of impending trouble.

With pumped fluid temperatures of up to 100°C (212°F), resulting bearing temperatures up to 100°C (212°F) are considered normal. The stability of the temperature rather than the number of degrees is the best indication of

normal operation. A sudden increase in temperature indicates that a bearing problem is developing, and a check of the bearing should be made.

When bearing temperature monitoring is utilized the bearing temperature alarm/shutdown settings should be set to the values stated in the **Lubricating oil requirements** section.



NOTICE:

Never throttle the pump flow from either the discharge or suction side. This action can result in decreased performance, unexpected heat generation, and equipment damage.

Risk of equipment damage from unexpected heat generation. Do not overload the driver. Ensure that the pump operating conditions are suitable for the driver. The driver can overload in these circumstances:

The viscosity of the fluid is greater than expected

The pumped fluid discharge pressure exceeds the pump rated pressure.

Check the bearing temperatures using a temperature-measuring device. Monitor the bearing temperature frequently during initial operation in order to determine if a bearing problem exists, as well as to establish normal bearing operating temperature.

For pumps with auxiliary piping, make sure that proper flows have been established and that the equipment is operating properly.

Establish baseline vibration readings in order to determine normal running conditions. If the unit is running roughly, then consult the factory.

Monitor all gauges to ensure that the pump is running at or near rating and that the suction screen (when used) is not clogged

Operation with excessive discharge pressure



WARNING:

Risk of breach of containment and equipment damage. Excessive vibration levels can cause damage to bearings, gears, seal chamber, and/or mechanical seal. Observe pump for vibration levels, bearing temperature, and excessive noise. If normal levels are exceeded, shut down and resolve.

Risk of explosion and serious physical injury. Do not operate pump with blocked system piping or with suction or discharge valves closed. This can result in rapid heating and vaporization of pumped fluid.

Risk of equipment damage and serious physical injury. Heat build-up can cause rotating parts to score or seize. Observe pump for excessive heat build-up. If normal levels are exceeded, shut down and resolve



NOTICE:

Cavitation can cause damage to the internal surfaces of the pump. Ensure net positive suction head available (NPSH_A) always exceeds NPSH required (NPSH_R) as shown on the published performance curve or datasheet of the pump

Operation under freezing conditions

**NOTICE:**

Do not expose an idle pump to freezing conditions. Drain all liquid that is inside the pump and any auxiliary equipment. Failure to do so can cause liquid to freeze and damage the pump.

Shut down the pump

**WARNING:**

Precautions must be taken to prevent physical injury. The pump may handle hazardous and/or toxic fluids. Proper personal protective equipment should be worn. Pumped fluid must be handled and disposed of in conformance with applicable environmental regulations

1. Shut down and lock out the driver to prevent accidental rotation.
2. Close the suction and discharge valves.
3. Close the seal line valves if fitted

Make the final alignment of the pump and driver

**WARNING:**

- Failure to disconnect and lock out driver power may result in serious physical injury or death. Always disconnect and lock out power to the driver before performing any installation or maintenance tasks.
- Electrical connections must be made by certified electricians in compliance with all international, national, state, and local rules.
- Refer to driver/coupling/gear manufacturer's installation and operation manuals (IOM) for specific instructions and recommendations.
- Misalignment can cause decreased performance, equipment damage, and even catastrophic failure leading to serious injury. Proper alignment is the responsibility of the installer and the user of the unit. Check the alignment of all drive components prior to operating the unit.
- Follow the coupling installation and operation procedures from the coupling manufacturer

You must check the final alignment after the pump and driver are at operating temperature.

For initial alignment instructions, see the Installation chapter.

1. Run the unit under actual operating conditions for enough time to bring the pump, driver, and associated system to operating temperature.
2. Shut down the pump and the driver.
3. Remove the coupling guard.
4. Check the alignment while the unit is still hot. See Pump-to-driver alignment in the Installation chapter.
5. Reinstall the coupling guard.

- Restart the pump and driver.

Dowelling the driver (Optional)

After the unit has been running for about one week, the coupling halves must be given a final check for possible misalignment caused by pipe strain or temperature strains. This check must be made immediately after unit is shut down, before it has a chance to cool.

If alignment is correct and unless Circor instructs otherwise, the driver should be doweled on diagonally opposite foot locations. Normally the pumps are doweled at the factory and the drivers are doweled in the field. The taper pin size for doweling the driver Position will normally be the same as the pump.

There are two methods employed by the factory for doweling the pump casing, depending on whether the pump is operated in an application with a low or high temperature differential between the ambient temperature during setup and the temperature of the pumped fluid. If the temperature differential is low the pump foot on the drive end of the pump will require taper pins installed to secure the pump to the baseplate. If the temperature differential is high the baseplate is supplied with provision to accommodate differential temperature doweling. This design ensures the alignment between the pump and driver is maintained while allowing the case to thermally move.



NOTICE:

You should dowel the driver only after completing the final hot alignment.

- Run the unit under actual operating conditions for enough time to bring the pump, driver and associated system to operating temperature.
- Shut down the pump and the driver.
- Remove the coupling guard.
- Check and confirm the alignment while the unit is still hot.
- Dowel the driver feet. See the driver IOM for details.



WARNING:

Failure to disconnect and lock out driver power may result in serious physical injury or death. Always disconnect and lock out power to the driver before performing any installation or maintenance tasks.

- Electrical connections must be made by certified electricians in compliance with all international, national, state, and local rules.
- Refer to driver/coupling/gear manufacturer's installation and operation manuals (IOM) for specific instructions and recommendations

Maintenance

Maintenance schedule

Maintenance inspections

A maintenance schedule includes these types of inspections:

- Daily routine inspections
- Weekly routine inspections
- Three-month inspections
- Annual inspections

Shorten the inspection intervals appropriately if the pumped fluid is abrasive or corrosive or if the environment is classified as potentially explosive.

Daily routine inspections

Perform these tasks whenever you check the pump during routine inspections:

- Check oil level in the bearing housings.
- Listen for unusual noise, vibration.
- Measure the bearing temperatures.
- Check the pump and piping for leaks.
- Check that there is no leakage from the mechanical seal.

Weekly routine inspections

Perform these tasks every week:

- Run any idle pumps under power.
- Check operation of suction and discharge valves
- Check all automatic controls and regulators

Three-month inspections

Perform these tasks every three months:

- Check that the foundation bolts are tight.
- Check the mechanical seal if the pump has been left idle and replace as required.
- For 216.40 pumps only, change the oil every three months (2000 hours) at minimum, or more often if there are adverse atmospheric or other conditions that might contaminate or break down the oil.
- Check the shaft alignment and realign as required.
- Check the pump and motor hold down bolts for proper tightness.

Annual inspections

Perform these inspections one time each year:

- Check the pump flow rate against a known differential pressure.
- Check the pump power consumption.

If the pump performance does not satisfy your process requirements, and the process requirements have not changed, then perform these steps:

1. Disassemble the pump in accordance with the disassembly section of this manual.
2. Inspect it in accordance with the inspection section of this manual
3. Repair or replace any worn or damaged parts.

Bearing maintenance (216.40 pumps only)

 These bearing lubrication sections list different temperatures of the pumped fluid. If the pump is ATEX-certified and the temperature of the pumped fluid exceeds the permitted temperature values, then consult your Circor representative.

Bearing lubrication schedule (216.40 pumps only)

Type of lubrication	First lubrication	Lubrication intervals
Oil	Add oil before you install and start the pump. Change the oil after 50 operating hours for new bearings.	After the first 50 operating hours, change the oil every 4000 operating hours.
Grease	Pump will be shipped with grease.	Bearings are Greased for Life.

Mechanical-seal maintenance



WARNING:

 The mechanical seal used in an EX- classified environment must be properly certified for the conditions of service.



CAUTION:

 Running a mechanical seal dry even momentarily can cause seal failure and physical injury. Never operate the pump without a reliable supply of liquid to the mechanical seal.

Mechanical seal maintenance

In addition to the routine inspections for leakage, the mechanical seal area should be kept free from the buildup of any crystallization of leakage, dust or debris. Maintaining a clean environment around the mechanical seal will be beneficial in allowing detection of increased leakage or another abnormal condition.

Disassembly

Disassembly precautions

**WARNING:**

- Failure to disconnect and lock out driver power may result in serious physical injury or death. Always disconnect and lock out power to the driver before performing any installation or maintenance tasks.
- Electrical connections must be made by certified electricians in compliance with all international, national, state, and local rules.
- Refer to driver/coupling/gear manufacturer's installation and operation manuals (IOM) for specific instructions and recommendations.
- Risk of serious personal injury. Applying heat to parts with internal cavities or reliefs can cause trapped liquid to rapidly expand and result in a violent explosion. This manual clearly identifies accepted methods for disassembling units. These methods must be adhered to. Never apply heat to aid in part removal unless it is explicitly stated in this manual
- Handling heavy equipment poses a crush hazard. Use caution during handling and wear appropriate Personal Protective Equipment (PPE, such as steel-toed shoes, gloves, etc.) at all times.
- Precautions must be taken to prevent physical injury. The pump may handle hazardous and/or toxic fluids. Proper personal protective equipment should be worn. Pumped fluid must be handled and disposed of in conformance with applicable environmental regulations.
- Risk of serious physical injury or death from rapid depressurization. Ensure pump is isolated from system and pressure is relieved before disassembling pump, removing plugs, opening vent or drain valves, or disconnecting piping.
- Risk of serious personal injury from exposure to hazardous or toxic liquids. A small amount of liquid will be present in certain areas like the seal chamber upon disassembly..

**CAUTION:**

Avoid injury. Worn pump components can have sharp edges. Wear appropriate gloves while handling these parts.

**NOTICE:**

This section of the IOM assumes that the user is trained and experienced in the assembly and disassembly of heavy, precision, industrial rotating machinery.

**** If you have any doubts regarding your capabilities to follow the instructions while applying appropriate levels of skill and care then please stop and seek assistance.****

Tools required

In order to disassemble the pump, you need these tools:

- Brass drift punch
- Cleaning agents and solvents

- Dial indicators
- Drill
- Feeler gauges
- Hex wrenches
- Induction heater
- Lifting sling
- Micrometers (inside and outside)
- Open end wrenches
- Press
- Soft face hammer
- Spanner wrench
- Spanning type puller
- Tap
- Torque wrench with sockets
- Lifting eyebolt (dependent on pump / motor size)

Prepare for disassembly

1. Close the isolation valves on the suction and discharge sides of the pump.
2. Drain the process fluid from the piping; flush the pump if necessary.
3. Disconnect all auxiliary piping, tubing, and coupling guard that will interfere with the removal of the pump assembly.
4. Remove shaft coupling with spanning type puller
5. Remove the oil drain plug (443) and sealing washer (479) from the bottom of the gear housing (406) and drain the oil/pumped fluid. Dispose of the oil/pumped fluid in accordance with applicable regulations
6. Loosen the relief valve guide rod and make sure the RV spring compression is released and brought to free length state.

Disassembly of the 216.40 pump (standard component method)



WARNING:

Lifting and handling heavy equipment poses a crush hazard. Use caution during lifting and handling and wear appropriate Personal Protective Equipment (PPE, such as steel-toed shoes, gloves, etc.) at all times. Seek assistance if necessary.

1. Remove screws (309) which secure the cover D (407) to the pump casing (350).

2. Use jackscrews tapped holes to break the bond between the cover D (407) and the pump casing (350). Continue to jack cover D (407) evenly until both bearings (103) are free of the screw shafts (100).
3. Remove cover D (407) intact with bearings (103), oil seals (721), seal cover (494), O-ring (703), screws (471), stationary mechanical seal seat (702) and anti-rotation pin (480).
4. Remove gasket (439)
5. Remove screws (310) which secure the gear housing (406) to the cover DF (401).
6. Use jackscrews tapped holes to break the bond between the gear housing (406) and the cover DF (401).
7. Remove gear housing (406), oil seal (704) and gasket (440) from the cover DF (401).
8. Remove both locknuts (110) to loosen both spur gears (108) from the screw shafts (100).
9. Remove both spur gears (108) from the screw shafts (100). Remove both keys (132).
10. Remove both distance bushings (124) from the gear side of the screw shafts (100).
11. Use a suitable manual or hydraulic tool to apply and even axial pressure to the DE shaft ends of both screw shafts (100). Using this tool press both screw shafts (100) until they are free of bearings (105).
12. Use jackscrews tapped holes to break the bond between the cover DF (401) and the pump casing (350).
 13. Remove cover DF (401) intact with bearings (105), oil seals (721), seal cover (494), O-ring (703), screws (471), stationary mechanical seal seat (702) and anti-rotation pin (480).
14. Remove gasket (439)
15. Remove both screw shafts (100) simultaneously out of the liner (352). Retain bushings (725, 726). It is not recommended to remove bushings (725, 726) unless they are worn. Remove the rotating portion of the mechanical seal (702) from screw shafts (100).
16. Remove the pump liner (352) from the pump casing (350).
17. Remove screws (471) then remove seal cover (494) and O-ring (703) from cover D (407). Remove the stationary portion of the seal (702), anti-rotation pin (480) and oil seals (721) from the seal cover (494).
18. Remove bearings (103) and oil seals (721) from cover D (407).
19. Remove screws (471) then remove seal cover (494) and O-ring (703) from cover DF (401). Remove the stationary portion of the seal (702), anti-rotation pin (480) and oil seals (721) from the seal cover (494).
20. Press out bearings (105) from cover DF (401).
21. Remove and retain shims (130), (131) from cover DF. It is recommended that the shims are match marked to assure current placement on reassembly.
22. Press out oil seal (704) from gearbox housing (406).

23. Dispose all single use items like gaskets, O-rings and lip seals with new parts as per safety policy.
24. Dispose the gearbox oil if the service time is completed as per safety policy.

Disassembly of the 216.10 pump (standard component method)



WARNING:

Lifting and handling heavy equipment poses a crush hazard. Use caution during lifting and handling and wear appropriate Personal Protective Equipment (PPE, such as steel-toed shoes, gloves, etc.) at all times. Seek assistance if necessary.

1. Remove screws (309) which secure the cover D (407) to the pump casing (350).
2. Use jackscrews tapped holes to break the bond between the cover D (407) and the pump casing (350). Continue to jack cover D (407) evenly until it is clear of both bearings (103).
3. Remove cover D (407)
4. Remove gasket (439)
5. Loosen fittings (714, 724). Remove the Plan 11 seal flush piping (712)
6. Remove screws (310) which secure the gear housing (406) to the cover DF (401).
7. Use jackscrews tapped holes to break the bond between the gear housing (406) and the cover DF (401).
8. Remove gear housing (406), stationary mechanical seal seat (702) and anti-rotation pin (480) and gasket (440) from the cover DF (401).
9. Remove the rotating portion of the mechanical seal (702) and bush (174) from screw shaft (100)
10. Remove both locknuts (110) to loosen both spur gears (108) from the screw shafts (100).
11. Remove both spur gears (108) from the screw shafts (100). Remove both keys (132).
12. Remove both distance bushings (124) from the gear side of the screw shafts (100).
13. Use a suitable manual or hydraulic tool to apply and even axial pressure to the DE shaft ends of both screw shafts (100). Using this tool press both screw shafts (100) until they are free of bearings (105).
14. Use jackscrews tapped holes to break the bond between the cover DF (401) and the pump casing (350).
15. Remove cover DF (401) intact with bearings (105), cover (494) and screws (471).
16. Remove gasket (439)
17. Remove both screw shafts (100) simultaneously out of the liner (352).
18. Remove the pump liner (352) from the pump casing (350).
19. Remove screws (471) then remove cover (494).
20. Press out bearings (105) from cover DF (401).

21. Remove and retain shims (130), (131) from cover DF. It is recommended that the shims are match marked to assure current placement on reassembly.
22. Press off bearings (103) from screw shafts (100).
23. Dispose all single use items like gaskets with new parts as per safety policy.

Preassembly inspections

Replacement guidelines

Casing check and replacement

**WARNING:**

Risk of death or serious injury. Leaking fluid can cause fire and/or burns. Replace all gaskets and O-rings at each overhaul or disassembly. Inspect all gasket and O-ring sealing surfaces for damage and repair or replace as necessary.

Inspect the body (350), liner (352), seal cover (470), cover D (407) and cover DF (401) for cracks and excessive wear or pitting. Thoroughly clean gasket surfaces and alignment fits to remove rust and debris.

Repair or replace these parts if you notice any of these conditions:

- Localized wear or grooving that is greater than 3.2mm (0.125in) deep
- Pitting that is greater than 3.2mm (0.125in) deep
- Irregularities such as heavy scratches, corrosion, denting etc. in the casing-gasket sealing surface. If the irregularity spans the sealing surface and is deeper than 15% of the gasket thickness, sealing integrity is likely to be impaired.
- Screw shaft to body clearances that exceed the values in the Minimum running clearances table by more than 50%.

**NOTICE:**

When clearances between the screw shaft and body become excessive (increase by 50%), hydraulic performance decreases substantially. High rated pressure differentials will tend to magnify any loss of hydraulic performance.

Body and seal housings areas to inspect

The arrows point to the areas to inspect for wear on the body (350), liner (352), seal cover (470), cover D (407) and cover DF (401):

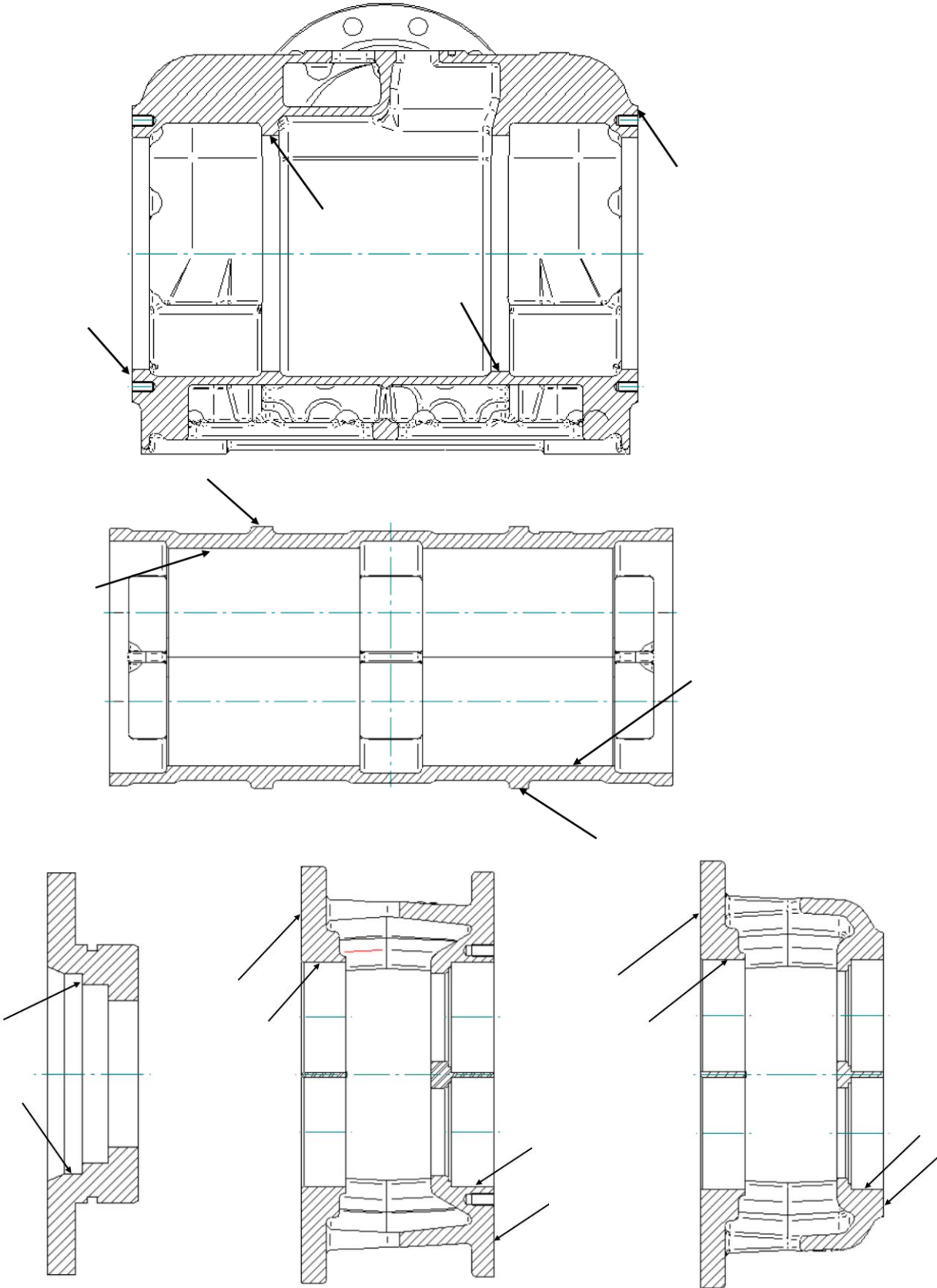

Body, liner, cover and seal housings areas

Screw shaft inspection

Inspect the screw shafts (100). Repair or replace these parts if you notice any of these conditions:

- Localized wear or grooving that is greater than 1.0mm (0.040in) deep
- Even wear in any location that is greater than 0.5mm (0.020in)
- Screw edges that exhibit cracks, pitting or corrosion damage.
- Screw shaft to body clearances that exceed the values in the Minimum running clearances table by more than 50%.

Check the screw shaft balance. Rebalance the screw shaft if it exceeds ISO 1940-1 grade 16. Note that some pumps are supplied with a higher grade of balance. If in doubt refer to the original order documentation for guidance.



NOTICE:

Protect machined surfaces while inspecting and cleaning the parts. Failure to do so may result in equipment damage.



NOTICE:

You must have access to the appropriate accurate fixtures equipment and balance techniques to successfully balance the screw shafts. Do not attempt to balance the screw shafts unless the equipment and an approved balance process is available. Failure to follow the correct process can result in irreversible damage to the screw shaft integrity.

Cartridge mechanical seal replacement

Cartridge-type mechanical seals should be serviced by the seal manufacturer. Refer to the instructions from the mechanical seal manufacturer for assistance.

Coupling guard replacement

Repair or replace the coupling guard if you notice corrosion or other defects.

Gaskets, O-rings, and seats replacement



WARNING:

Risk of death or serious injury. Leaking fluid can cause fire and/or burns. Replace all gaskets and O-rings at each overhaul or disassembly. Inspect all gasket and O-ring sealing surfaces for damage and repair or replace as necessary.

Fasteners

**WARNING:**

Risk of serious personal injury or property damage. Fasteners such as bolts and nuts are critical to the safe and reliable operation of the product. Ensure appropriate use of fasteners during installation or reassembly of the unit.

- Use fasteners of the proper size and material only.
- Replace all damaged or corroded fasteners.
- Ensure that all fasteners are properly tightened and that there are no missing fasteners.

Additional parts

Inspect and either repair or replace all other parts, if inspection indicates continued use would be harmful to satisfactory and safe pump operation. Inspection must include these items:

- Gear housing (406) and bearing housings (401) (407)
- Oil seals (704) (721)
- Bearing locknut (110)
- Coupling key (133)
- All nuts, bolts, dowels and screws

Screw shaft replacement guidelines

Screw shaft measurement check

Check the mechanical seal, bearing and gear wheel fits of the screw shafts (100) using outside precision micrometers with a measurement sensitivity of 0,0025mm (0.0001in). If any are outside the tolerances shown in the fits and tolerances table, then replace the screw shaft.

Screw shaft inspection



NOTICE:

Do not use the screw shaft centers for the runout check as they may have been damaged during the removal of the bearings or gears.

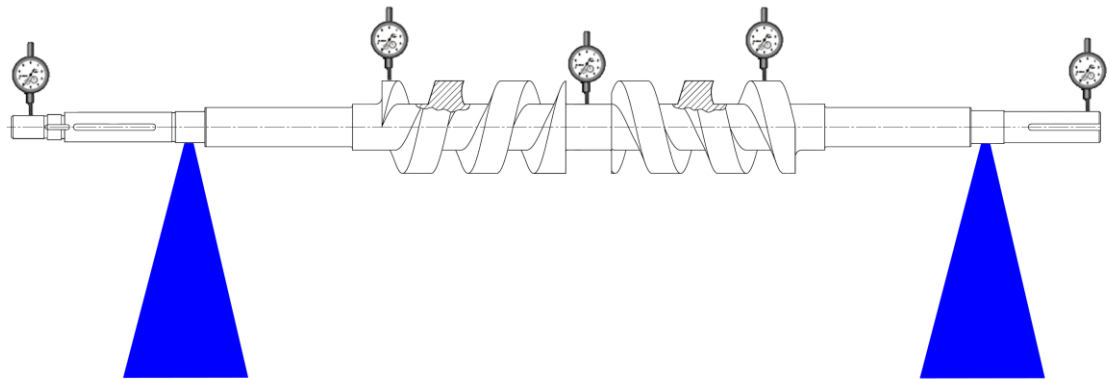

Screw shaft inspection

Screw shaft runout check

Using precision “V” blocks support the screw shaft at the two bearing locations shown. Rotate the shaft slowly by gripping the coupling location. Be sure not to apply excessive force which might deflect the shaft and can result in a false reading. Use a rigidly supported precision dial with a measurement sensitivity of 0.0025mm (0.0001in). The measured runout of the screw shaft should not exceed 0.05mm (0.002in) at any location.

Bearings inspection

Condition of bearings

Do not reuse bearings as this is typically a false economy. The remaining life available on a bearing cannot be determined through simple inspection. The condition of the bearings will provide useful information on the operating conditions seen by the bearings in the bearing frame.

Checklist

Perform these checks when you inspect the bearings (103), (105):

- Note the lubricant condition – color, smell, free water and residue. For example, a burnt aroma or cloudiness of the lubricant can indicate abnormal operation. In such cases further oil analysis from a specialist company is recommended.
- Inspect the bearings to see if they are loose, rough, or noisy when you rotate them. In the case of separable bearings, inspect each component individually noting the location and magnitude of wear.
- Investigate any abnormal lubricant or bearing damage to determine the cause. If the cause is not normal wear, correct the issue before you return the pump to service.

Replacement bearings

Replacement bearings (103), (105) must be the same as, or equivalent to, those listed in these tables.

Size	Front Bearing	Rear Bearing	Bearing Housing ID		Screw shaft OD	
			mm (inch)		Mm (inch)	
Part #	-105	-103	-407	-401	-101	-102
88	3206	6206	62.018 (2.4416)	62.018 (2.4416)	30.011 (1.1815)	30.011 (1.1815)
			61.988 (2.4404)	61.988 (2.4404)	30.002 (1.1811)	30.002 (1.1811)
105	3306	6306	72.018 (2.8353)	72.018 (2.8353)	30.011 (1.1815)	30.011 (1.1815)
			71.988 (2.8341)	71.988 (2.8341)	30.002 (1.1811)	30.002 (1.1811)
118	3307	6307	80.018 (3.1503)	80.018 (3.1503)	35.013 (1.3784)	35.013 (1.3784)
			79.988 (3.1491)	79.988 (3.1491)	35.002 (1.3780)	35.002 (1.3780)
135	3308	6308	90.022 (3.5441)	90.022 (3.5441)	40.013 (1.5753)	40.013 (1.5753)
			89.987 (3.5427)	89.987 (3.5427)	40.002 (1.5748)	40.002 (1.5748)
150	3309	6309	100.022 (3.9378)	100.022 (3.9378)	45.013 (1.7721)	45.013 (1.7721)
			99.987 (3.9364)	99.987 (3.9364)	45.002 (1.7717)	45.002 (1.7717)
165	3310	6310	110.022 (4.3315)	110.022 (4.3315)	50.013 (1.9690)	50.013 (1.9690)
			109.987 (4.3301)	109.987 (4.3301)	50.002 (1.9685)	50.002 (1.9685)
180	3311	6311	120.022 (4.7252)	120.022 (4.7252)	55.015 (2.1659)	55.015 (2.1659)
			119.987 (4.7238)	119.987 (4.7238)	55.002 (2.1654)	55.002 (2.1654)
195	3312	6312	130.026 (5.1191)	130.026 (5.1191)	60.015 (2.3627)	60.015 (2.3627)
			129.986 (5.1175)	129.986 (5.1175)	60.002 (2.3622)	60.002 (2.3622)

Size	Front Bearing	Rear Bearing	Bearing Housing ID		Screw shaft OD	
			mm (inch)		Mm (inch)	
Part #	-105	-103	-407	-401	-101	-102
210	3313	6313	140.026 (5.5128)	140.026 (5.5128)	65.015 (2.5596)	65.015 (2.5596)
			139.986 (5.5112)	139.986 (5.5112)	65.002 (2.5591)	65.002 (2.5591)
225	3314	6314	150.026 (5.9065)	150.026 (5.9065)	70.015 (2.7564)	70.015 (2.7564)
			149.986 (5.9049)	149.986 (5.9049)	70.002 (2.7559)	70.002 (2.7559)

Bearing housings

Perform these checks when you inspect the bearing housings:

- Check that the bearing housings are clean, with no burrs or other surface damage.
- Check the bearing housing bores against the values in the bearing fits table.
- Repair or replace housings as necessary.

Replacement oil seals (216.40 pump only)

Replacement oil seals (704) (721) must be the same as, or equivalent to, those listed in this table.

Size	Inboard oil seal	DE oil seal
Part #	-721	-704
88	Viton Ø35xØ50x10 DIN 3760A	VitonØ28xØ47x10 DIN 3760A
105	VitonØ40xØ58x10 DIN 3760A	VitonØ28xØ47x10 DIN 3760A
118	VitonØ45xØ65x10 DIN 3760A	VitonØ32xØ52x10 DIN 3760A
135	Viton Ø50xØ72x10 DIN 3760A	Viton Ø38xØ56x10 DIN 3760A
150	VitonØ55xØ80x10 DIN 3760A	VitonØ42xØ62x10 DIN 3760A
165	Viton Ø60xØ85x10 DIN 3760A	VitonØ45xØ65x10 DIN 3760A
180	Viton Ø68xØ90x10 DIN 3760A	Viton Ø50xØ70x10 DIN 3760A
195	Viton Ø75xØ100x13 DIN 3760A	VitonØ55xØ80x10 DIN 3760A
210	Viton Ø80xØ100x13DIN3760A	Viton Ø60xØ80x12 DIN 3760A
225	Viton Ø85xØ120x12 DIN3760A	Viton 65x95x10 DIN 3760A

Reassembly of the 216.40 pump (standard component method)

**WARNING:**

Lifting and handling heavy equipment poses a crush hazard. Use caution during lifting and handling and wear appropriate Personal Protective Equipment (PPE, such as steel-toed shoes, gloves, etc.) at all times. Seek assistance if necessary.

**NOTICE:**

Make sure that all parts and threads are clean and that you have followed all directions under the inspections section. Deburr parts if necessary. Apply a Molybdenum based anti-seize compound with a 0.15 friction coefficient to all the threads.

**WARNING:**

 Check for magnetism on the screw shafts (100) and demagnetize the shaft if there is Magnetism detected. Magnetism attracts ferritic objects to the mechanical seal, gears and bearings which can result in excessive heat generation, sparks, and premature failure.

1. Insert liner (352) into the pump casing (350). Check that the liner (352) is axially centered in the pump casing (350).
2. Pair both screw shafts (100) on a flat surface and center them axial to each other (align the rotors axial so that the shoulders of the thrust-bearings are axially aligned to each other)
3. Install the dowel pins (375, 376) if they were removed.
4. If bushings (725, 726) were removed from screw shafts (100) install the bushings with Loctite® 638 or equivalent. Install the rotating portion of the mechanical seal (702) onto screw shafts (100).
5. Insert shims (130), (131) into cover DF.
6. Working with cover DF (401) press in bearings (105)
7. Install oil seals (721) into covers (494).
8. Install covers (494) and screw (471) into cover DF (401). Secure screws (471) with Loctite® 243 or equivalent. Install the stationary portion of mechanical seal (702) into covers 494.
9. Clamp or otherwise brace the screw shafts (100). Assemble cover DF (401) onto the screw shafts until no gap remains between bearings (105) and bushings (725).
10. Verify that the correct flank to flank clearance between the screw shafts (100) exists. If necessary, adjust the shim stack thickness for shims (130), (131) and repeat steps 5. to 9. until acceptable flank to flank clearance is achieved.
11. Verify that the axial setting position of the mechanical seals is correct.
12. Install both distance bushes (124) onto the gear side of the screw shafts (100).
13. Install both keys (132) then install both spur gears (108) onto the screw shafts (100)
14. Install both locknuts (110) with Loctite® 243 or equivalent.

15. Install gaskets (439) onto the pump casing (350).
16. Install the subassembly of screw shafts (100) and cover DF (401) into the pump casing (350) and liner (352). Temporarily secure cover DF (401) to the pump casing (350) with screws (310).
17. Working with cover D (407) press in bearings (103)
18. Install oil seals (721) into covers (494).
19. Install covers (494) and screw (471) into cover D (407). Secure screws (471) with Loctite® 243 or equivalent. Install the stationary portion of mechanical seal (702) into covers 494.
20. Install cover D (407) onto pump casing (350) and secure with screws (309). Verify that the screw shafts turn freely without binding or tight spots.
21. Remove temporarily installed screws (310) from cover DF (401)
22. Press oil seal (704) into gear housing (706)
23. Install gasket (440). Install gear housing (406) and secure with screws (310).
24. Close the gear housing (406) drain port using plug (443) and sealing washer (479).
25. Fill the gear housing (406) with the correct oil to the center of the sight glass and close the filling port.
26. Close all support threads or bores with permanent plugs.
27. Check for oil leaks and correct oil levels.

Reassembly of the 216.10 pump (standard component method)

**WARNING:**

Lifting and handling heavy equipment poses a crush hazard. Use caution during lifting and handling and wear appropriate Personal Protective Equipment (PPE, such as steel-toed shoes, gloves, etc.) at all times. Seek assistance if necessary.

**NOTICE:**

Make sure that all parts and threads are clean and that you have followed all directions under the inspections section. Deburr parts if necessary. Apply a Molybdenum based anti-seize compound with a 0.15 friction coefficient to all the threads.

**WARNING:**

 Check for magnetism on the screw shafts (100) and demagnetize the shaft if there is Magnetism detected. Magnetism attracts ferritic objects to the mechanical seal, gears and bearings which can result in excessive heat generation, sparks, and premature failure.

1. Insert liner (352) into the pump casing (350). Check that the liner (352) is axially centered in the pump casing (350).
2. Pair both screw shafts (100) on a flat surface and center them axial to each other (align the rotors axial so that the shoulders of the thrust-bearings are axially aligned to each other)
3. Install the dowel pins (375, 376) if they were removed.
4. If bushings (725, 726) were removed from screw shafts (100) install the bushings with Loctite® 638 or equivalent. Install the rotating portion of the mechanical seal (702) onto screw shafts (100).
5. Insert shims (130), (131) into cover DF.
6. Working with cover DF (401) press in bearings (105)
7. Install covers (494) and screw (471) into cover DF (401). Secure screws (471) with Loctite® 243 or equivalent.
8. Clamp or otherwise brace the screw shafts (100). Assemble cover DF (401) onto the screw shafts until no gap remains between bearings (105) and bushings (725).
9. Verify that the correct flank to flank clearance between the screw shafts (100) exists. If necessary, adjust the shim stack thickness for shims (130), (131) and repeat steps 5. to 9. until acceptable flank to flank clearance is achieved.
10. Install both distance bushes (124) onto the gear side of the screw shafts (100).
11. Install both keys (132) then install both spur gears (108) onto the screw shafts (100)
12. Install both locknuts (110) with Loctite® 243 or equivalent.
13. Install gaskets (439) onto the pump casing (350).

14. Install the subassembly of screw shafts (100) and cover DF (401) into the pump casing (350) and liner (352). Temporarily secure cover DF (401) to the pump casing (350) with screws (310).
15. Install bearings (103) onto screw shafts (100)
16. Install cover D (407) onto pump casing (350) and secure with screws (309). Verify that the screw shafts turn freely without binding or tight spots.
17. Remove temporarily installed screws (310) from cover DF (401)
18. Install bush (174) and the rotating portion of mechanical seal (702) onto screw shaft (100).
19. Install the stationary portion of mechanical seal (702) into gear housing (406).
20. Install gasket (440). Install gear housing (406) and secure with screws (310).
21. Close the gear housing (406) drain port using plug (443) and sealing washer (479).
22. Install the Plan 11 seal flush piping (712). Tighten fittings (714, 724).
23. Close all support threads or bores with permanent plugs.

Machinery Inspection Record Sheet

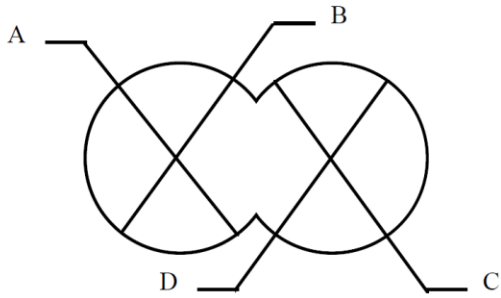

1.	SCREW #1	SCREW #2
2.		
3.		
4.		
5.	SCREW #3	SCREW #4
6.		

	A	B	C	D
1.				
2.				
3.				
4.				
5.				
6.				

FLANK CLEARANCE
 Screws 1 & 2 _____
 Screws 3 & 4 _____

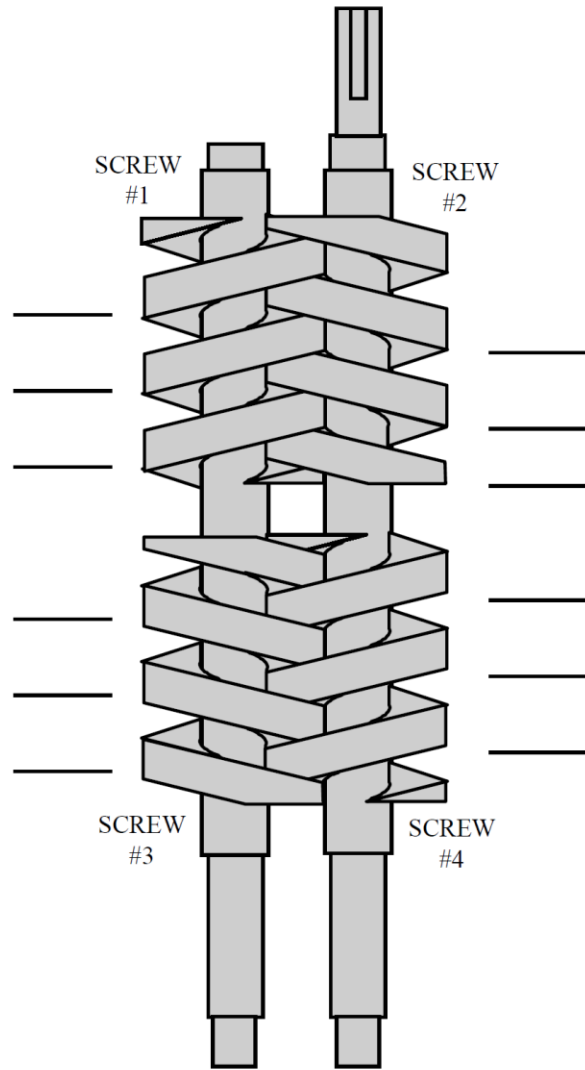

	Long Shaft	Short Shaft
RUNOUT		
cpl brgs	_____	_____
inb tg brgs	_____	_____
otb tg brgs	_____	_____
t gear area	_____	_____
cpl end hub	_____	_____

≠

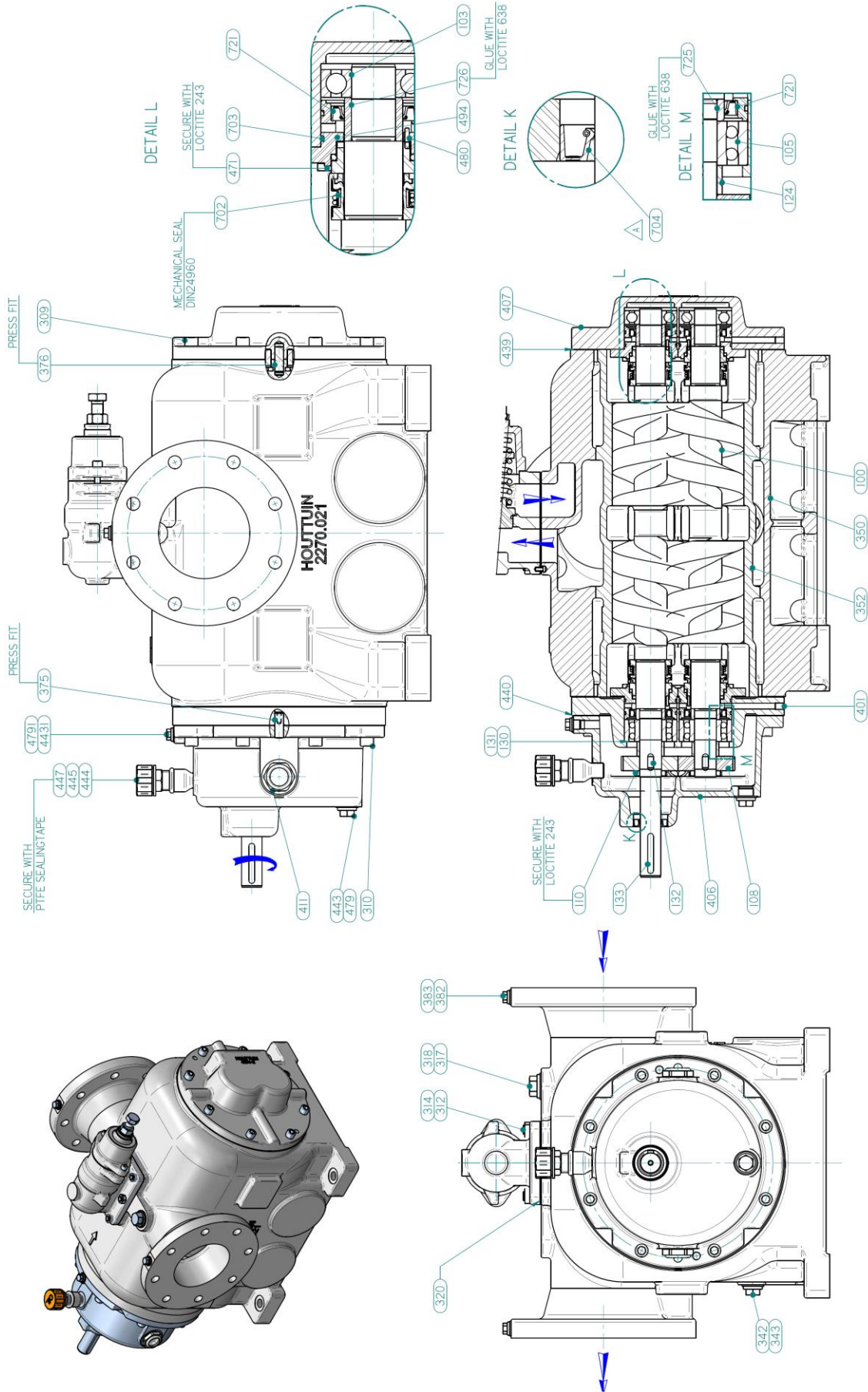

Spare parts

**NOTICE:**

When ordering spare parts, the following information should be indicated on the purchase order.

- Pump serial number (see Name plate).
- Pump series (see Name plate)

**NOTICE:**

To ensure a safe and good functioning of the pump we advise to buy genuine spare parts according the specifications in the parts list. Usage of non-genuine parts may void warranty.

Minor Kit

The purpose of this kit is to enable the user to have immediate access to routine maintenance parts for use during pump commissioning or for emergency repair during the first two years of operation.

Major Kit

The purpose of this kit is to enable the user to have immediate access to routine maintenance parts for use during pump commissioning or for emergency repair during the first five years of operation. The kit contains a factory timed rotating assembly as well as all the parts found in the Minor Kit.

216.40 Pump

DWG ITEM#	SPARE PART DESCRIPTION	MINOR KIT QTY	MAJOR KIT QTY
103	BEARING, RADIAL	2	
105	BEARING, THRUST	2	
439	GASKET, PUMP BODY TO COVER	2	
440	GASKET, COVER DF TO GEAR BOX HOUSING	1	
479	GASKET WASHER, GEAR HOUSING DRAIN	1	
702	MECHANICAL SEAL	4	
703	"O" RINGS, COVER TO SEAL COVER	4	
704	LIP SEAL (DE)	1	
721	LIP SEAL (INBOARD)	4	
	LOCTITE® 243 RETAINING COMPOUND	1 TUBE	
*	MINOR KIT (SEE ALL ITEMS ABOVE)		1
100	SCREW SET		1
108	TIMING GEAR (MATCHED SET OF TWO)		1
110	LOCKNUT		2
124	DISTANCE BUSH		2
130	SHIM		2
131	SHIM		2
132	TIMING GEAR KEY		2
133	SHAFT KEY		1
352	LINER		1
375	DOWEL (COVER TO GEAR CASING)		2
376	DOWEL (COVER TO PUMP CASING)		4
725	BUSH		2
726	BUSH		2
	LOCTITE® 638 RETAINING COMPOUND	1 TUBE	

216.10 Pump

DWG ITEM#	SPARE PART DESCRIPTION	MINOR KIT QTY	MAJOR KIT QTY
103	BEARING, RADIAL	2	
105	BEARING, THRUST	2	
439	GASKET, PUMP BODY TO COVER	2	
440	GASKET, COVER DF TO GEAR BOX HOUSING	1	
479	GASKET WASHER, GEAR HOUSING DRAIN	1	
702	MECHANICAL SEAL	1	
	LOCTITE® 243 RETAINING COMPOUND	1 TUBE	
*	MINOR KIT (SEE ALL ITEMS ABOVE)		1
100	SCREW SET		1
108	TIMING GEAR (MATCHED SET OF TWO)		1
110	LOCKNUT		2
124	DISTANCE BUSH		2
130	SHIM		2
131	SHIM		2
132	TIMING GEAR KEY		2
133	SHAFT KEY		1
174	BUSH		1
352	LINER		1
375	DOWEL (COVER TO GEAR CASING)		2
376	DOWEL (COVER TO PUMP CASING)		4

Troubleshooting

Operation troubleshooting

Symptom	Cause	Remedy
The pump is not delivering liquid.	The pump is not primed.	Re-prime the pump and check that the pump and suction line are full of liquid.
	The suction lift is too high.	Shorten the suction pipe and/or increase the diameter and/or reduce the number of “lossy” fittings.
	The pump is rotating in the wrong direction.	Change the rotation. The rotation must match the rotation arrow on the pump.
	The foot valve or suction pipe opening is not submerged enough.	Increase the submersion depth. Use a baffle in order to eliminate vortices.
	Air leaks into the suction line or pump	Locate the source of the air leak and rectify. Typical locations are single mechanical seals (without quench), flange gaskets and valve stem packings.
	The suction pipe is clogged.	Remove the obstruction from the suction pipe.
	Relief valve is incorrectly set.	Adjust relief valve to open at the set pressure indicated on the pump nameplate.
The pump is not producing the rated flow.	The operating speed is too low (when a VFD or gearbox is used)	Verify the VFD settings and correct as required. Verify the motor and/or gearbox nameplate speeds and change out if necessary.
	The foot valve or suction pipe has high losses.	Shorten the suction pipe and/or increase the diameter and/or reduce the number of “lossy” fittings.
	Air leaks into the suction line or pump	Locate the source of the air leak and rectify. Typical locations are single mechanical seals (without quench), flange gaskets and valve stem packings.
	The suction pipe is partly clogged.	Remove the obstruction from the suction pipe.
	Relief valve is incorrectly set.	Adjust relief valve to open at the set pressure indicated on the pump nameplate.
	The suction lift is too high.	Make sure that the suction-line shutoff valve is fully open and that the line is unobstructed. Verify the minimum suction pressure or liquid level is within specification. Verify the fluid vapor pressure is within specification
	The liquid is less viscous than specified	Bring the liquid viscosity to within specification or have the pump rerated for the new condition.
	The discharge pressure is too high	Bring the discharge pressure to within specification or have the pump rerated for the new condition.
	The pump is worn or damaged.	Inspect and replace the pump if necessary.

Symptom	Cause	Remedy
The pump starts pumping but then loses suction.	The pump is not fully primed.	Re-prime the pump and check that the pump and suction line are full of liquid.
	The suction line has air or vapor pockets.	Rearrange the piping in order to eliminate air pockets.
	Air leaks into the suction line or pump	Locate the source of the air leak and rectify. Typical locations are single mechanical seals (without quench), flange gaskets and valve stem packings.
	Off-gassing of air or vapor from the pumped liquid	Verify the minimum suction pressure or liquid level is within specification. Verify the fluid vapor pressure is within specification
	The pump is worn or damaged.	Inspect and replace the pump if necessary.
The bearings are running hot.	The pump and driver are not aligned properly.	Realign the pump and driver.
	The bearings are worn or damaged	Replace the bearings
	The discharge pressure is too high	Bring the discharge pressure to within specification.
	The operating speed is too high	Bring the pump speed to within specification.
	There is insufficient lubrication.	Check the lubricant for suitability and level.
The pump is noisy or vibrates.	The pump and driver are not aligned properly.	Realign the pump and driver.
	The pump is worn or damaged.	Inspect and replace the pump if necessary.
	The motor has high vibration which is being transmitted to the pump.	Verify the source of the motor vibration and repair as needed.
	The foundation arrangement is not rigid.	Tighten the hold-down bolts of the pump and motor. Make sure the baseplate is properly grouted without voids or air pockets.
	The bearings are worn or damaged	Replace the bearings
	The suction or discharge piping is not anchored or properly supported.	Anchor the suction or discharge piping as necessary according to recommendations in the Hydraulic Institute Standards Manual.
	Relief valve chatter	Adjust relief valve to open at the set pressure indicated on the pump nameplate.
	The suction velocity is too high.	Increase the suction pipe diameter.
	The suction lift is too high.	Make sure that the suction-line shutoff valve is fully open and that the line is unobstructed. Verify the minimum suction pressure or liquid level is within specification. Verify the fluid vapor pressure and viscosity is within specification
	Off-gassing of air or vapor from the pumped liquid	Verify the minimum suction pressure or liquid level is within specification. Verify the fluid vapor pressure is within specification

Symptom	Cause	Remedy
The mechanical seal is leaking excessively.	The mechanical seal parts are worn.	Replace the worn parts.
	The mechanical seal is overheating.	Check the flushing and cooling lines.
	Suction pressure is above the rated value	Reduce the suction pressure
	Barrier pressure is above the rated value	Reduce the barrier pressure
	The screw shaft is scored at the mechanical seal location.	Repair or replace the screw shaft as necessary.
The motor requires excessive power.	The discharge line is obstructed.	Remove the discharge line obstruction.
	The liquid is more viscous than specified.	Bring the liquid viscosity to within specification or have the pump and motor rerated for the new condition.
	The discharge pressure is too high	Bring the discharge pressure to within specification or have the pump and motor rerated for the new condition.
	The pump is worn or damaged.	Inspect and replace the pump if necessary.

Alignment troubleshooting

Symptom	Cause	Remedy
Horizontal (side-to-side) alignment cannot be obtained (angular or parallel).	The driver feet are bolt-bound.	Loosen the pump's hold-down bolts and slide the pump and driver until you can achieve horizontal alignment.
	The baseplate is not leveled properly and is twisted.	<ol style="list-style-type: none"> Determine which corners of the baseplate are high or low. Remove or add shims at the appropriate corners. Realign the pump and driver.
Vertical (top-to-bottom) alignment cannot be obtained (angular or parallel).	The baseplate is not leveled properly and is bowed.	<ol style="list-style-type: none"> Determine if the center of the baseplate should be raised or lowered. Level screws equally at the center of the baseplate. Realign the pump and driver.

Supplemental assembly information

Maximum torque values for fasteners

TORQUE TABLE						
Thread	Torque for Type 8.8 (Nm)	Torque for Type 8.8 (In-lbs)	Torque for Type 10.9 (Nm)	Torque for Type 10.9 (In-lbs)	Torque for Type 12.9 (Nm)	Torque for Type 12.9 (In-lbs)
M6 x 1,00	11.3	100	16.5	146	19.3	171
M8 x 1,25	27.3	241	40.1	355	46.9	415
M10 x 1,50	54	478	79	699	93	823
M12 x 1,75	93	823	137	1212	160	1416
M16 x 2,00	230	2036	338	2991	395	3496
M20 x 2,50	464	4106	661	5850	773	6841
M24 x 3,00	798	7062	1136	10054	1329	11762
M27 x 3,00	1176	10408	1674	14815	1959	17337
M30 x 3,50	1597	14133	2274	20125	2662	23559
M33 x 3,50	2161	19125	3078	27240	3601	31869
M39 x 4,00	3597	31833	5123	45339	5995	53056

Recommended torquing sequence for bolted joints

1. Always use a high-quality calibrated torque wrench
2. Work in a “Criss-Cross” star pattern for circular joints
3. Work in a Spiral pattern for non-circular joints
4. Use the **Rule of 3** for tightening
5. The first pass of tightening should be to approximately 1/3rd of the final fastener torque
6. The second pass should be to 2/3rd of the final fastener torque
7. The third pass should be to 100% of the final faster torque
8. Make one final pass to verify all the fasteners have stabilized at the target torque.

