

**ALL-PURPOSE
BALANCED
CAGE-GUIDED
CONTROL VALVES
ANSI CLASS 150-1500
2" TO 16" (50MM TO 400MM)**

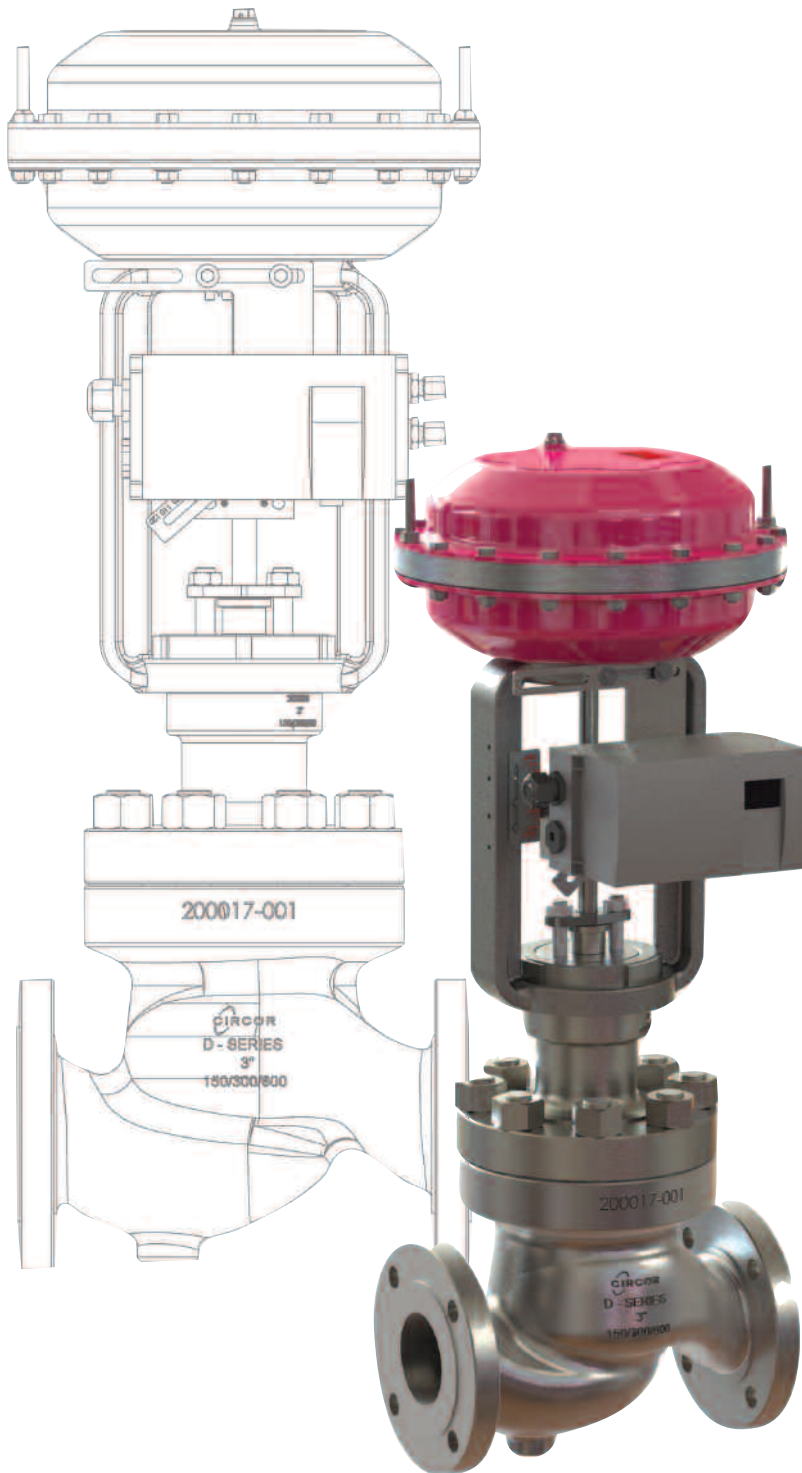

**Simple Design
Simple Operation
Simple Maintenance**



D-Series

Rugged Cage Guiding * Hardened Trim Materials * Multi-Stage, Anti-Noise & Anti-Cavitation Trim



Leslie Controls RTK Mallard Control

Product Information



SIMPLY THE BEST!

D-Series from Circor is the next generation of the reliable and proven DBOY control valve. The D-Series is an all-purpose cage-guided, balanced control valve. This new product offers simplicity of design in a valve platform that is well suited for the needs of power, process, and general industry. A wider selection of valve sizes, materials, and noise / cavitation trims allows application across a broader range of flow rates, pressures and temperatures.

HARDENED STAINLESS STEEL TRIM

Standard valve trim consists of heat-treated and hardened 400 series stainless steel providing maximum hardness with excellent wear properties, in addition, 316 stainless steel is offered for superior corrosion resistance. Seating surfaces can be additionally armored with a nickel/cobalt overlay (Stellite®) on the 316 stainless steel base material providing significantly longer service life than 316 stainless steel trims.

CAGE OPTIONS

Interchangeable trim and cages offer maximum versatility in flow control applications.

Cage variations include:

- reduced trim which provides capacities of 80%, 60%, or 40% of full trim capacity. This feature can be used to control valve body velocities, to plan for future flow expansion, or to correct for oversized conditions.
- Les-Cav cage effectively prevents any valve trim damage due to valve cavitation.
- Les-Sonic cage effectively reduces noise at the source in either a single-stage or two-stage construction.

BALANCED PLUG DESIGN

The balanced plug design of the D-Series equalizes line pressure under the plug with pressure above the plug, effectively cancelling any unbalanced stem force due to pressure drop. In addition to providing smooth, high-pressure control, balanced plugs allow use of smaller, lighter, cost-effective actuators. Class III, IV or V shut off can be provided.



Accelerating Growth

HIGH FLOW CAPACITIES

D-Series flow capacities are greater than or equal to competing product. Optimized flow geometry reduces body velocities and pressure losses, maximizing valve body life.

CAGE RETAINED SEAT DESIGN

Unlike some competing designs, which use complicated seat retention methods, the D-Series cage and seat ring are clamped in place between the bonnet and body. This design eliminates the maintenance problems associated with removal of bolted-in seat rings.

RUGGED PLUG SEAL

D-Series heavy cupwasher style PTFE plug seal has three times the cross-sectional area and wear surface of competing designs with minimal friction for tightest resolution. Pressure energized to provide a tight seal at low and high pressures, D-Series seal provides tight shut-off for longer than competitive designs.

RELIABLE ACTUATOR CONNECTION

D-Series actuators are clamped in place with a simple and reliable yoke lock nut. Actuator mounting guarantees ease of disassembly no matter how corrosive the environment.

REDUCED SEAT WEAR/ TIGHTER SHUT-OFF

D-Series control valves are specifically designed for high pressure drop service. Pressure drop, high velocities and throttling occur only at the cage window and the plug, thereby protecting the seat ring and tight shut-off capability of the valve.

D-SERIES SPECIFICATIONS

BODY ASSEMBLY: Style: Single seated, top entry bolted bonnet, globe style body, (Optional: angle-style), cage-guided balanced plug

SIZE, RATINGS & ENDCONNECTIONS:

2" - 8", Class 150, 300, 600, 900, 1500 RF, RTJ, BWE
10" - 16" Class 150, 300, 600, RF, BWE, RTJ

BODY/BONNET MATERIALS:

Carbon Steel, A216 Gr WCC: -20 to 800°F (-29°C to 427°C)
Low-Temp Carbon Steel A352 Gr. LCC: -50 to 800°F (-46°C to 427°C)
316 Stainless Steel, A351 Gr CF8M: -50 to 1000°F (-46°C to 538°C)
Chrome-Moly Steel A217 Gr WC9: -20 to 1000°F (-29°C to 538°C)

BODY/BONNET BOLTING:

Standard, -20 to 800°F (-28°C to 427°C)
ASTM A-193 GR B7 Studs, ASTM A-194 GR 2H Nuts
High Temp, 800-1000°F (427°C to 538°C)
ASTM A-193 GR B16 Studs, ASTM A-194 GR 4 or 7 Nuts

STEM PACKING:

Braided PTFE with Kevlar filaments, Temp: -20.2°F to 446°F (-29°C to 230°C)
Graphite - 2 Anti-Extrusion Ring Graphoil, Temp: -20.2°F to 1050°F (-29°C to 566°C)
-40 to 500°F (-22 to 260°C)
Laminated Graphite, -320 to 1000°F (-195 to 538°C)

PACKING STUDS, NUTS & FOLLOWER:

300 Series Stainless Steel

GASKETS:

Body/Bonnet and Seat Ring/Body:
For up to 6" sizes: Spiral Wound 316L/Graphite 1000°F (+566°C) Max.
Above 6" sizes: Spiral Wound 316L/Graphite 449.6°F (232°C) Max.
Flexible Graphite: 1000°F (538°C) Max.

TRIM SIZES:

Full Port, 80%, 60% and 40% Reduced Port.
Custom Cv: contact Application Engineering

PLUG (PISTON) SEAL MATERIALS:

C300 (C300 spring loaded seal) with Inconel Spring:
Up to 572°F (300°C). Class IV or V
Double Carbon-Graphite seal rings: Up to 1000°F (538°C). Class IV

FLOW CHARACTERISTICS:

Linear, and Equal Percentage

SHUTOFF CLASS (ANSI /ISA 70-2):

Standard trim, -20 to 572°F (-18 to 300°C). Class V
to 800F (427°C). Class IV
High-temp trim, 1000°F (538°C). Class IV

TRIM MATERIAL COMBINATIONS:

	PLUG	CAGE	SEAT RING
Martensitic STD	410 Hardened	410 Hardened	410 Hardened
Martensitic HI-TEMP	CA6NM Nitrided	CA6NM Nitrided	CA6NM Nitrided
Austemtic STD	316	316	316
Austemtic HI-TEMP	ASTM A487 CA6NM	ASTM A487 CA6NM	ASTM A487 CA6NM

ACTUATORS:

Standard: Spring and Diaphragm
Optional: Piston, Double Acting/Spring Return, Hydraulic, Electric, Electro-Hydraulic

D-Series Features & Benefits

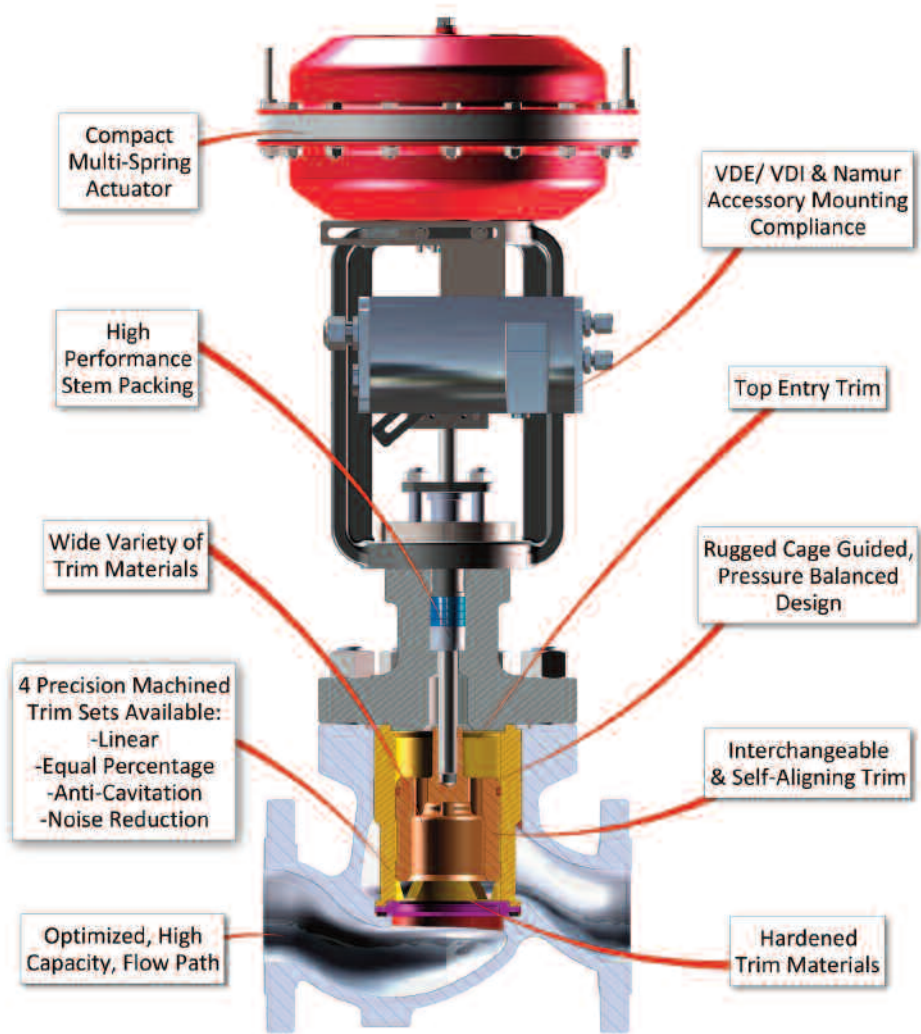

Feature	Advantage	Benefit
Rugged, Pressure-Balanced Design	Allows for the Use of Smaller Actuators	Lower Initial Cost
Multi-stage, Anti-Noise, Anti-Cavitation Trims	Efficient Energy Dissipation	Longer Life of Valve Assets
Optimized , High Capacity Flow Path	Higher Cv per Size than Majority of Valves in its Class	Lower Initial Costs
Compact Multi-Spring Actuator	Reduced Height and Weight	Lower Installation Costs
Industry Standard Accessory Mounting	Accommodates most valve automation products	Lower Automation Costs
Interchangeable, Top-Entry, & Self-Aligning Trim	Flexibility of Applications, Ease of Access, and High Alignment Integrity	Reduced Spare Inventory Cost
High-Performance, High Temp, Stem Packing	Reduced Leakage, Lower Fugitive Emissions	Improved Environmental Compliance
4 Precision Machined Trim Sets Available	Highly Accurate and Repeatable Throttling Control	Improved Product Yield & Quality Control
Hardened Trim Materials with Wide Variety of Material Selection	Longer Life and Greater Flexibility	Reduced Operating and Maintenance Costs, Longer Service Life

Key Target Applications

The D-Series is well suited for a variety of general service applications as well as moderate noise and cavitation abatement services.

Feedwater Control regulates level of water in the boiler drum.

Auxiliary Steam Pressure Reduction Valve

- 1) Sootblower: increases thermal efficiency by controlling steam supplied from superheated source.
- 2) Building Heat: Used for extraction steam control
- 3) Pegging Steam Control: Control of superheated steam to remove air from condensate at deaerator

Drain Valve prevents the presence of condensate in the turbine at startup or shutdown

Gland Seal Steam Valve is used to maintain constant gland stem pressure to seal air from the turbine.

Attemperator Spray, Superheat and Reheat Valve controls steam temperature to the turbine. In superheat applications this valve requires high control accuracy; in reheat spray applications cavitation control and shutoff integrity are required.

Other Applications: Condensate recirculation, condensate blow down control, reheat atmospheric vent and fuel gas control in power plant operations. Steam management and major equipment protection (pumps and compressors) in Oil & Gas service, as well as a variety of applications in oil refining, gas processing, natural gas storage and LNG and gas transmission.

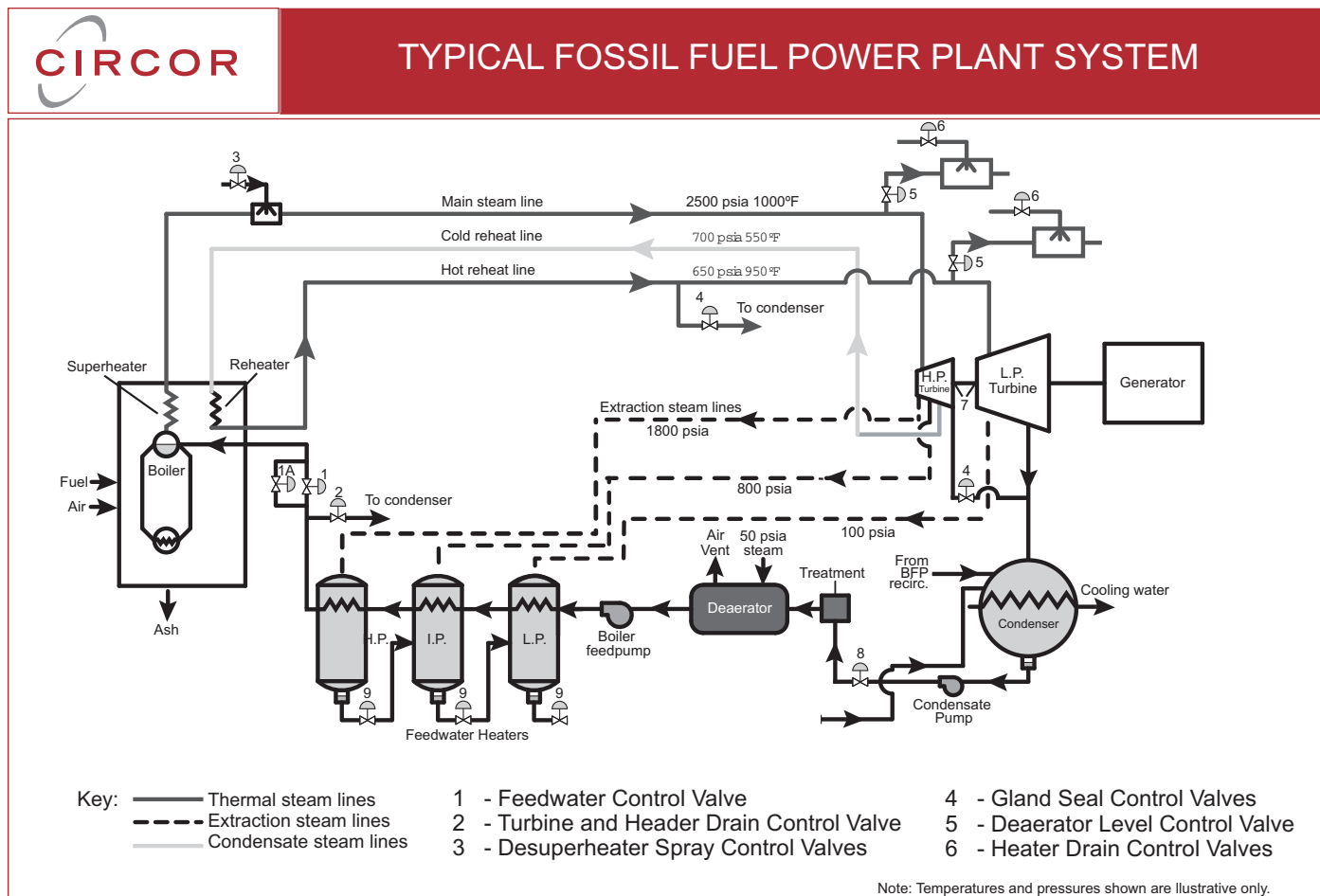

D-Series Rugged Cage Design



Standard Cage

The full ported, standard cage, provides maximum flow with minimum pressure drop. The inherent linear or equal percent flow characteristic provides excellent low flow control, high rangeability and maximum Cv per inch.

Anti-Cavitation Cage

The Les-Cav cage controls the effects of valve cavitation providing a normal valve/trim life expectancy in cavitating conditions. Diametrically opposed holes, increase the valves cavitation index (Kc) and direct impinging flow to the center of the cage, preventing mechanical trim/body damage.



Reduced Trim Cage

This optional cage reduces the maximum Cv and flow to 80%, 60% or 40% of the normal full port valve. Used to provide body velocity control, future flow expandability, or to correct for oversized valve conditions.

Noise Reducing Cage

The Les-Sonic cage is designed to reduce fluid generated noise up to 15 - 20dBA in steam, gas or any compressible fluid service. When used in conjunction with a Les-Sonic silencing orifice, noise attenuation of greater than 20dBA can be achieved.



D-Series C_v Table

Valve Size (in)	DN	Rating	Full EQ%	60% EQ%	Full Linear	60% Linear	Les-Sonic I Single Stage	Les-Cav I Single Stage
2	50	150-1500	68	41	75	45	68	84
3	80	150-1500	140	84	155	93	135	152
4	100	150-1500	216	130	240	144	208	193
6	150	150-1500	400	240	450	270	366	406
8	200	150-600	756	454	800	480	698	578
		900-1500	680	408	720	432	712	502
10	250	150-600	1100	660	1300	780	997	953
12	300	150-600	1440	864	1800	1080	1114	1095
16	400	150-600	2300	1380	3100	1860	2322	1749

Actuator Offerings

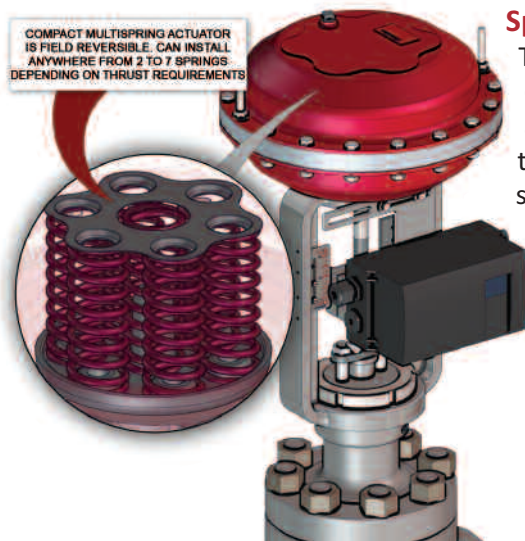

Spring & Diaphragm Actuator

The D Series is available with a multi-spring diaphragm actuator which delivers excellent control performance in a compact package. This actuator design is based on decades-proven and highly reliable diaphragm technology. The spring and diaphragm actuator provides for inherent fail safe operation and can be easily reversed between direct and reverse acting function. Standard positioners and a variety of accessories cleanly mount on this actuator.

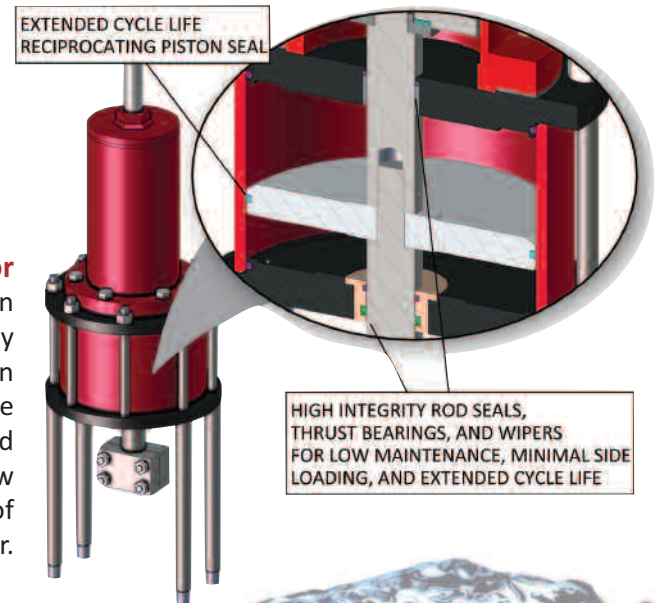

Piston Actuator

The D Series is also available with a powerful piston actuator. This actuator provides high thrust for its size by taking advantage of higher air supply pressures. The piston actuator offers precise control performance, long stroke capability, and stiffness that effectively buffers high fluid dynamic forces experienced in more extreme flow conditions. Standard positioners and a variety of accessories cleanly mount on this actuator.

Standard D-Series Accessories

Positioners

- Pneumatic Siemens Model 760P
- Electropneumatic Siemens Model 760E
- Siemens PS2
- Optional internal limit switches
- Optional valve positions transmission

Process Controllers

- Electropneumatic: PMC-2
- Pneumatic: PDAP/PRAP
- Pneumatic: Mallard 3350/3360

Solenoid Valves

- ASCO 8320G174

Noise Reduction Devices

- Noise Suppressor
- Les-Sonic Silencing Orifice

Air Regulators

- ASG-1
- AFG-2

Manual Override Handwheels

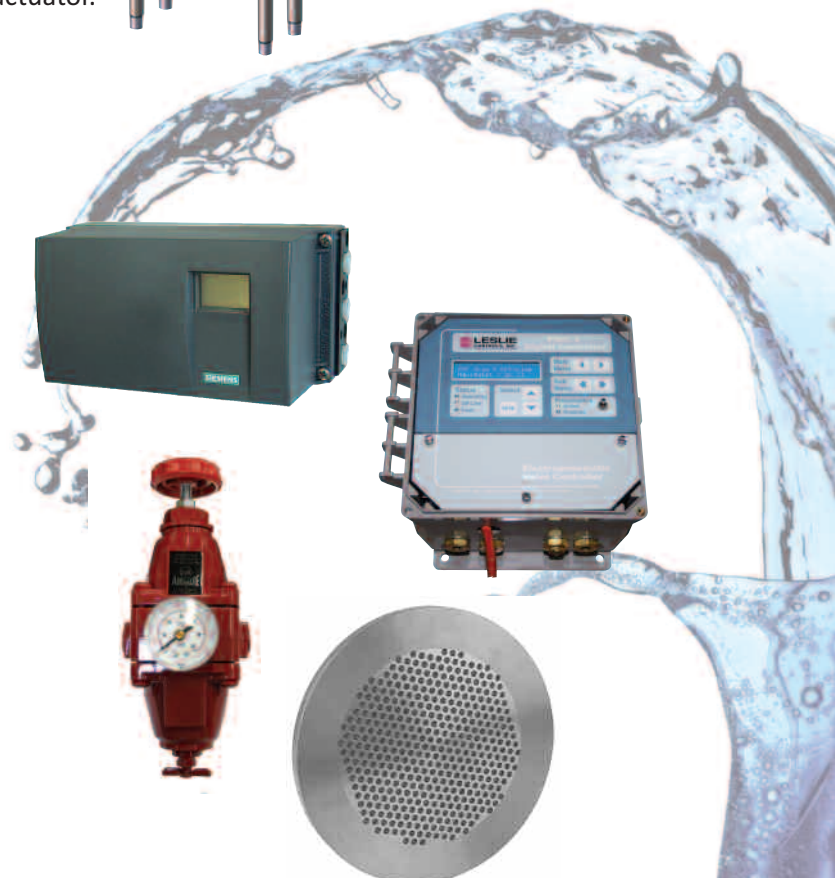

The D-Series is Available From:



A global manufacturer specializing in highly engineered, complex and severe environment products that serve long-term, high-growth infrastructure markets, including upstream oil and gas, power generation and aerospace.

...and is Marketed Under the Following CIRCOR Brands:

Leslie Controls

Leslie Controls, Inc. has designed and manufactured valves for the power generation, industrial, marine and oil and gas markets for over a century. From high quality regulators with 99% accuracy to severe service control valves that provide **ZERO LEAKAGE**, Leslie Controls products are known throughout the world. Customers also rely on Leslie for engineered solutions for their most difficult applications. Leslie's Quick Delivery program provides a broad range of standard product within **five** days.

RTK

Regeltechnik Kornwestheim (RTK) has more than 35 years experience in the manufacture and sales of control valves and is a leading European manufacturer of industrial valves. RTK delivers innovative products and services that **improve thermal efficiency** and system safety for all heating and refrigeration processes. RTK offers control valves, electric and pneumatic actuators, sensors and controllers engineered for thermal control applications in general industry, as well as auxiliary boiler and water treatment applications in power generation.

Mallard Control

Mallard Control is a premier supplier of measurement and control solutions to the oil and gas industry. Our products (control valves, regulators, relief valves, controllers, switches, and gauges) cover virtually every production facility instrumentation requirement, providing customers easy access to **top-quality equipment from a single source** at the most competitive price.

