

D-SERIES CONTROL VALVE

SIZES 2" – 16" (PN 50 - 400)

ANSI CLASS 150# to 1500# (PN 16 - 250)

- **High Flow Capacities** promote reduced body velocity and reduce pressure loss
- **Balanced Plug Design** provides smooth high pressure control
- **Multiple Cage Options** for maximum versatility
- **Cup Seal** with three times the wear surface of competitive valves for long-lasting leak tight seal
- **Hardened/Stainless Steel Trim** provides twice the service life of 316 stainless trim
- **Tighter Shutoff** design provides exceptional performance up to Class V
- **Temperature Rating** up to 1,000F (538°C)
- **Ultra Compact Actuators** install in tight spaces
- **Yoke Lock Nut** guarantees easy disassembly

MATERIALS

- Carbon Steel - Standard WCC, -20°F to +800°F (-28.9°C to +426.7°C), Optional LCC, -50°F to 800°F (-45.5°C to +427°C)
- 316 Stainless Steel (CF8M)
- Chrome Moly Steel (WC9)

APPLICABLE INDUSTRY STANDARDS

See Control Valve Handbook - Reference Section on Page 195

APPLICATION DATA

- Control systems for Power, Chemical, Petrochemical, Pulp and Paper, Food, & other industries
- HVAC systems
- Feedwater and fuel system controls in boiler rooms
- Packaged systems (OEM) such as heat exchangers, water purification systems & vaporizers, metal cleaning and plating

OPTIONS

- Multi-Spring, Single-Spring, & Piston Actuators Available
- Threaded, Socketweld, Flanged, Butt weld End, and RTJ Connections
- Positioners (Pneumatic/Electronic/Digital)
- Two-Stage Noise and Cavitation Reducing Trim
- Reduced Flow Cages (0.8, 0.6, 0.4 Factor)
- Alternate Packing sets for Severe Service
- High Temperature Trim

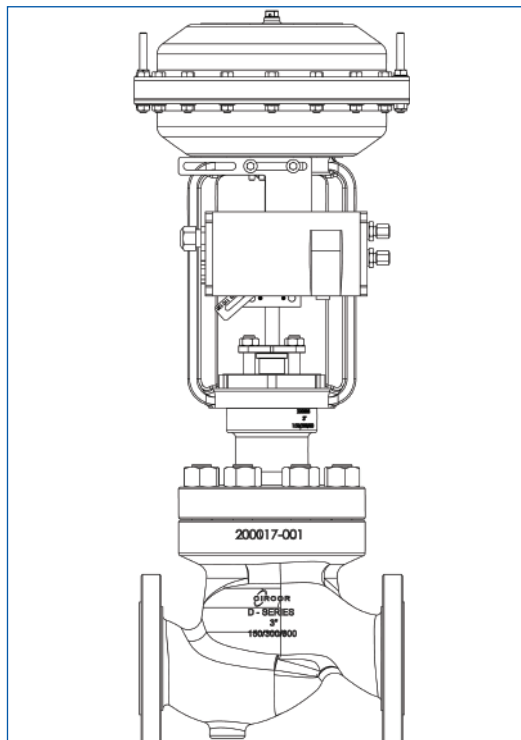

D-SERIES CONTROL VALVE

Dimensions & Weights

"A", "B" and "C" DIMENSIONS inches (mm)⁽¹⁾

Size	THD	Raised Face (A)					B					C	
	NPT	150	300	600	900	1500	150	300	600	900	1500	150 ~ 1500	
2 (50)	11.26 (286.0)	10.0 (254)	10.51 (267)	11.26 (286)	14.76 (375)	14.76 (375)	2.76 (70)	2.76 (70)	2.76 (70)	2.87 (73)	2.87 (73)	8.84 (224.5)	
2½ (65)	-	-	-	-	-	-	-	-	-	-	-	-	
3 (80)	-	11.732 (298)	12.52 (318)	13.27 (337)	17.36 (441)	18.11 (460)	3.54 (90)	3.54 (90)	3.54 (90)	30.54 (90)	3.77 (96)	11.14 (283)	
4 (100)	-	13.86 (352)	14.49 (368)	15.51 (394)	20.11 (511)	20.86 (530)	3.94 (100)	3.94 (100)	3.94 (100)	4.64 (118)	5.31 (135)	11.89 (302)	
6 (150)	-	17.76 (451)	18.62 (473)	20.0 (508)	28.11 (714)	30.23 (768)	5.91 (150)	5.91 (150)	5.91 (150)	6.77 (172)	7.28 (185)	14.10 (358)	
8 (200)	-	21.34 (543)	22.36 (568)	24.02 (610)	35.98 (914)	38.26 (972)	7.60 (193)	7.60 (193)	7.60 (193)	8.66 (220)	9.50 (241)	16.78 (426)	
Raised Face (A)							B					C	
												150 ~ 300	600
10 (254)	-	26.5 (673)	27.9 (708)	29.6 (752)	-	-	9.7 (245)		9.3 (235)	-	-	22.7 (576)	23.0 (586)
12 (305)	-	29.0 (737)	30.5 (775)	32.2 (819)	-	-	10.6 (270)			-	-	23.9 (606)	24.0 (611)
16 (406)	-	40.0 (1016)	41.6 (1057)	43.6 (1108)	-	-	13.2 (334)	13.6 (344.5)	13.8 (350)	-	-	23.5 (599)	

⁽¹⁾NPT Available in 2" only.

"A", "B" and "C" DIMENSIONS inches (mm)

Size	Butt Weld End (A)						B					C	
	NPT	150	300	600	900	1500	150	300	600	900	1500	150 ~ 1500	
2 (50)		11.25 (286)			14.80 (375)		2.76 (70)	2.76 (70)	2.76 (70)	2.87 (73)	2.87 (73)	8.84 (224.5)	
2½ (65)	-	-	-	-	-	-	-	-	-	-	-	-	
3 (80)	-	13.26 (337)			18.11 (460)		3.54 (90)	3.54 (90)	3.54 (90)	30.54 (90)	3.77 (96)	11.14 (283)	
4 (100)	-	15.50 (394)			20.90 (530)		3.94 (100)	3.94 (100)	3.94 (100)	4.64 (118)	5.31 (135)	11.89 (302)	
6 (150)	-	20.00 (508)			30.23 (768)		5.91 (150)	5.91 (150)	5.91 (150)	6.77 (172)	7.28 (185)	14.10 (358)	
8 (200)	-	24.00 (610)			32.75 (832)		7.60 (193)	7.60 (193)	7.60 (193)	8.66 (220)	9.50 (241)	16.78 (426)	
Butt Weld End (A)							B					C	
												150 ~ 300	600
10 (254)	-	29.6 (752)	29.6 (752)	-	-		9.7* (245)		9.3 (235)	-	-	22.7 (576)	23.0 (586)
12 (305)	-	32.2 (819)	32.2 (819)	-	-		10.6* (270)			-	-	23.9 (606)	24.0 (611)
16 (406)	-	43.6 (1108)	43.6 (1108)	-	-		13.6 (344.5)	13.8 (350)	-	-	23.5 (599)		

*Designs vary to meet required Cv s

D-SERIES CONTROL VALVE

Dimensions & Weights

"A", "B" and "C" DIMENSIONS inches (mm)

Size	Ring type joint (A)						B					C		
	NPT	150	300	600	900	1500	150	300	600	900	1500	150~300	600	150 ~ 1500
2 (50)		10.50 (267)	11.14 (283)	11.37 (289)	14.88 (378)	14.88 (378)	2.76 (70)	2.76 (70)	2.76 (70)	2.87 (73)	2.87 (73)	-	-	8.84 (224.5)
2½ (65)	-	-	-	-	-	-	-	-	-	-	-	-	-	-
3 (80)	-	12.244 (311)	13.12 (334)	13.40 (340)	17.50 (444)	18.22 (463)	3.54 (90)	3.54 (90)	3.54 (90)	30.54 (90)	3.77 (96)	-	-	11.14 (283)
4 (100)	-	14.37 (365)	15.10 (384)	15.62 (397)	20.23 (514)	21.00 (533)	3.94 (100)	3.94 (100)	3.94 (100)	4.64 (118)	5.31 (135)	-	-	11.89 (302)
6 (150)	-	18.26 (464)	19.25 (489)	20.11 (511)	28.22 (717)	30.50 (774)	5.91 (150)	5.91 (150)	5.91 (150)	6.77 (172)	7.28 (185)	-	-	14.10 (358)
8 (200)	-	21.90 (556)	23.00 (584)	24.13 (613)	36.10 (917)	38.70 (982)	7.60 (193)	7.60 (193)	7.60 (193)	8.66 (220)	9.50 (241)	-	-	16.78 (426)
10 (254)	-	27.0 (686)	28.5 (724)	29.7 (755)	-	-	9.7 (245)		9.3 (235)	-	-	22.7 (576)	23.0 (586)	-
12 (305)	-	29.5 (750)	31.1 (791)	32.4 (822)	-	-	10.5 (270)			-	-	23.9 (606)	24.0 (611)	-
16 (406)	-	40.5 (1029)	42.2 (1073)	43.7 (1111)	-	-	13.2 (344)	13.6 (344.5)	13.8 (350)	-	-	23.5 (599)		-

"D" DIMENSIONS inches (mm)

Size	M42 (ST 6135)	M82 (ST 6160)		M155 (ST 6175)	
	STROKE 1.4" (35 mm)	STROKE 1.6" (40 mm)	STROKE 2.4" (60 mm)	STROKE 2.4" (60 mm)	STROKE 4" (100 mm)
2 (50)	14.8 (376)	16.0 (406)	16.8 (426)	19.2 (489)	TBD
2½ (65)	-	-	-	-	-
3 (80)	-	-	14.5 (446)	19.2 (489)	TBD
4 (100)	-	-	14.5 (446)	19.2 (489)	TBD
6 (150)	-	-	-	-	TBD
8 (200)	-	-	-	-	26.6 (675)
10 (254)	-	-	-	-	26.6 (675)
12 (305)	-	-	-	-	26.6 (675)
16 (406)	-	-	-	-	26.6 (675)
Weight Pounds (Kg)	11.0 (5)	27.5 (12.5)	33.0 (15)	122.0 (55)	165.0 (75)

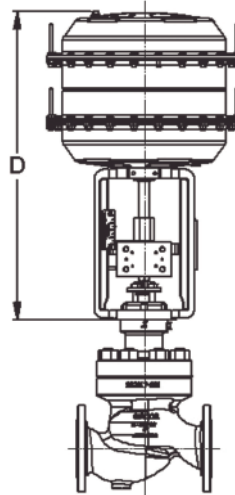

Multi-Spring Actuator
M155 100 mm Stroke

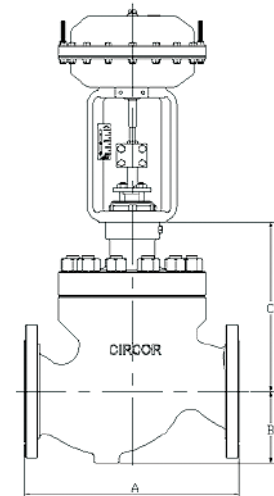

Multi-Spring Actuator
Standard

"D" DIMENSIONS inches (mm)

SI.No	Actuator model	Dimension 'D' mm (Inch)	Weight Kg (lbs)
1	P25	561 (22.1)	28 (61.7)
2	P50	777.5 (30.6)	57 (125.6)
3	P75	1014 (39.9)	107 (235.9)
4	P150	1098 (43.2)	205 (451.9)
5	P200	1139 (44.8)	328 (723.1)

1. Weights are approximate
2. Weights are only for actuator-assembly

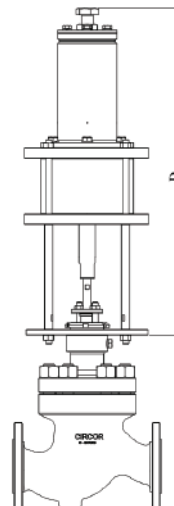

Piston Actuator

D-SERIES CONTROL VALVE

Dimensions & Weights⁽¹⁾ - Pounds (kg)⁽²⁾⁽³⁾

Size	THD	Raised Face Body				
	NPT ⁽¹⁾	150	300	600	900	1500
2 (50)	50.7 (23.0)	50.7 (23.0)	58.2 (26.4)	61.7 (28.0)	119.0 (54.0)	119.0 (54.0)
2½ (65)	-	-	-	-	-	-
3 (80)	-	105.4 (47.8)	117.3 (53.2)	123.0 (55.8)	204.2 (92.6)	243.6 (110.5)
4 (100)	-	158.7 (72)	176.4 (80)	201.7 (91.5)	333.75 (151.4)	403.0 (182.8)
6 (150)	-	275.6 (125)	326.3 (148)	395.1 (179.2)	577.4 (261.9)	843.9 (382.8)
8 (200)	-	553.8 (251.2)	603.6 (273.8)	816.8 (370.5)	1021.6 (463.4)	1469.4 (666.5)
10 (254)	-	683 (310)	877 (398)	1281 (581)	-	-
12 (305)	-	1032 (468)	1327 (602)	1847 (838)	-	-
16 (406)	-	1656 (751)	2277 (1033)	3084 (1399)	-	-

Size	Ring Type Joint Body				
	150	300	600	900	1500
2 (50)	51.6 (23.4)	59.5 (27.0)	62.2 (28.2)	120.2 (54.5)	120.2 (54.5)
2½ (65)	-	-	-	-	-
3 (80)	107.6 (48.8)	120.6 (54.7)	124.1 (56.3)	205.7 (93.3)	245.8 (111.5)
4 (100)	161.6 (73.3)	182.3 (82.7)	202.6 (91.9)	335.5 (152.2)	405.4 (183.9)
6 (150)	277.8 (126.0)	332.6 (150.9)	397.0 (180.1)	578.7 (262.5)	848.1 (384.7)
8 (200)	558.2 (253.2)	612.9 (278.0)	820.1 (372.0)	1026.3 (465.5)	1480.2 (671.4)
10 (254)	690 (313)	888 (403)	1285 (583)	-	-
12 (305)	1043 (473)	1343 (609)	1852 (840)	-	-
16 (406)	1669 (757)	2299 (1043)	3093 (1403)	-	-

Size	Butt Weld End Body				
	150	300	600	900	1500
2 (50)	51.4 (23.3)			86.6 (39.3)	
2½ (65)	-	-	-	-	-
3 (80)	98.3 (44.6)			185.2 (84.0)	
4 (100)	148.2 (67.2)			316.1 (143.4)	
6 (150)	298.7 (135.5)			647.5 (293.7)	
8 (200)	704.8 (319.7)			1015.0 (460.4)	
10 (254)	807 (366)	-	-	1049 (476)	-
12 (305)	1199 (544)	-	-	1572 (713)	-
16 (406)	2044 (927)	-	-	2635 (1195)	-

1. NPT available in 2" only
2. Weights are approximate
3. Weights are only for body sub-assembly

D-SERIES CAGE DESIGN (OPTIONS)

Interchangeable trim and cages offer maximum versatility in flow control applications. Cage variations include:

- Reduced trim which provides capacities of 80%, 60% or 40% of full trim capacity. This feature can be used to control valves body velocities, to plan for future flow expansion, or to correct for oversized conditions.
- Les-Cav cage effectively prevents any valve trim damage due to valve cavitation in either a single-stage or two-stage construction.
- Les-Sonic cage effectively reduces noise at the source in either a single-stage or two-stage construction.

LINEAR



STANDARD CAGE

The full ported, standard cage provides maximum flow with minimum pressure drop. The inherent linear or equal percent flow characteristic provides excellent low flow control, high rangeability and maximum Cv per inch.

REDUCED TRIM CAGE

This optional cage reduces the maximum Cv and flow to 80%, 60% or 40% of the normal, full port valve. Used to provide body velocity control, future flow expandability, or to correct for oversized valve conditions.

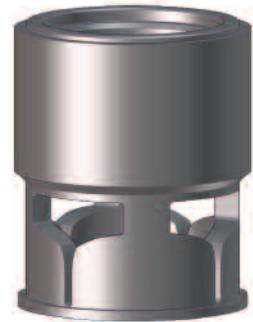

ANTI-CAVITATION CAGE

The Les-Cav cage controls the effects of valve cavitation, with single or dual stages, providing a normal valve/trim life expectancy in cavitating conditions. Diametrically opposed holes increase the valves cavitation index (Kc) and direct impinging flow to the center of the cage, preventing mechanical trim/body damage.

NOISE REDUCING CAGE

The Les-Sonic cage is designed to reduce fluid generated noise up to 15 - 20 dBA, with single or dual stages, in steam, gas or any compressible fluid service. When used in conjunction with a Les-Sonic silencing orifice, noise attenuation of greater than 20 dBA can be achieved.



Single Stage / 2 Stages

PACKING CONFIGURATIONS

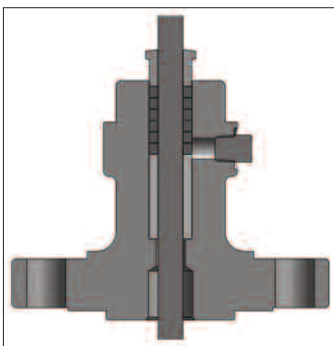

SINGLE PTFE

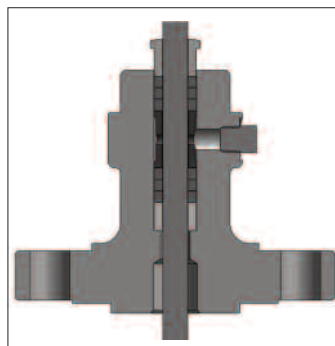

DOUBLE PTFE

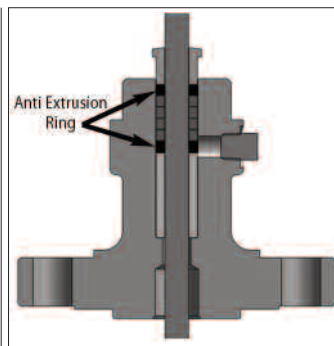

SINGLE LAMINATED GRAPHITE

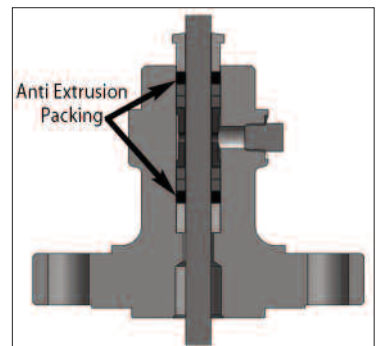

DOUBLE LAMINATED GRAPHITE

Braided PTFE V-ring packing provides the most maintenance free stem seal manufactured from the purest PTFE yarns with an Aramid core. Maximum service temperature is 428°F (220°C).

Precision die-cut laminated graphite rings provide a reliable, tight stem seal to operating temperatures of 1000°F (538°C)

D-SERIES TRIM MATERIAL SELECTION

Balanced Plug design allows line pressure under the plug to build up above the plug, effectively cancelling out any unbalanced stem force due to pressure. In addition to providing smooth, high pressure control, balanced plugs allow use of small, light, cost effective actuators. Class IV or V shutoff can be provided.

TRIM MATERIAL COMBINATIONS:

Trim Type	Trim	Maximum Service Temp.	Plug	Seat Ring	Stem	Plug Seal	Shutoff
Standard Balanced	410 STD	800°F/427°C	SS 410 Hardened	SS 410 Hardened	A479 TY316	C300 spring loaded seal 572°F/300°C - Flex Graph. 800°F/427°C	V or IV
	316 STD	800°F/427°C	A351 CF8M	A351 CF8M	A479 TY316	C300 spring loaded seal 572°F/300°C - Flex Graph. 800°F/427°C	V or IV
	316 Errosive	800°F/427°C	A351 CF8M Stellited	A351 CF8M Stellited	A479 TY316	C300 spring loaded seal 572°F/300°C - Flex Graph. 800°F/427°C	V or IV
High Temp	CA6NM HI-TEMP	1000°F/538°C	ASTM A487 CA6NM (Nitrided)	ASTM A487 CA6NM	ASTM A638 GR 660/Inconel X750	Flex Graph.	IV

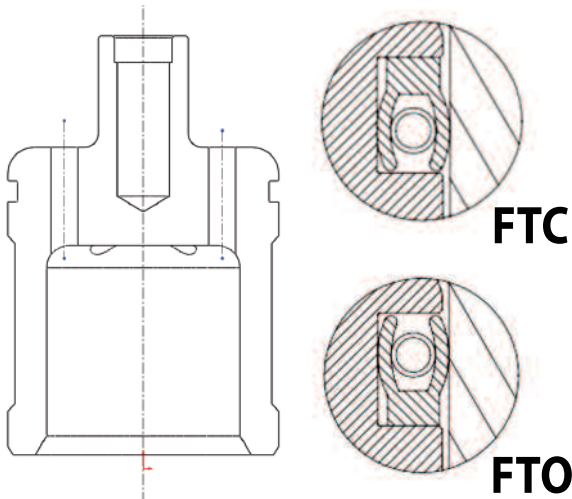

STANDARD BALANCED PLUG

Balanced plug design eliminates large stem forces allowing the use of small, responsive, cost-effective actuators. Provides smooth throttling control even at pressures to 1000 psi. Our C300 spring loaded seal utilizes a special alloy and inconel spring to provide ANSI class IV or V shutoff to temperatures of 572°F (300°C).

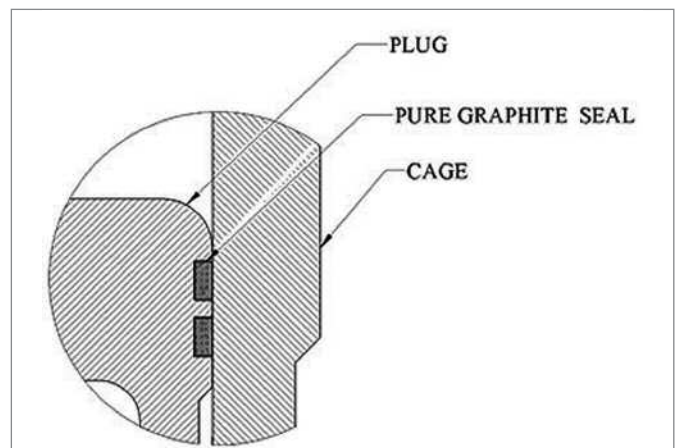

HIGH-TEMP BALANCED PLUG

Balanced plug with high-temp carbon seal rings provides ANSI Class IV shutoff at temperatures up to 1000°F (538°C).

D-SERIES SPECIFICATIONS

BODY ASSEMBLY:

Style: Single seated, top entry, bolted bonnet, globe style body (optional: angle-style), cage-guided balanced plug

SIZE, RATINGS & END CONNECTIONS:

2" thru 8", Class 150, 300, 600, 900, 1500 RF, RTJ, BWE
10" thru 16" Class 150, 300, 600, RF, BWE, RTJ

BODY/BONNET MATERIALS:

Carbon Steel, A216 Gr WCC,
-20 to 800°F (-29°C to 427°C)
Low-Temp Carbon Steel A352 Gr. LCC,
-50 to 800°F (-46°C to 427°C)
316 Stainless Steel, A351 Gr CF8M,
-50 to 1000°F (-46°C to 538°C)
Chrome-Moly Steel A217 Gr WC9
-20 to 1000°F (-29°C to 538°C)

BODY/BONNET BOLTING:

Standard, -20 to 800°F (-28 to 427°C)
ASTM A-193 GR B7 Studs
ASTM A-194 GR 2H Nuts
High Temp, 800-1000°F (427 to 538°C)
ASTM A-193 GR B16 Studs
ASTM A-194 GR 4 or 7 Nuts

STEM PACKING:

Braided PTFE with Kevlar filaments
Temp. -20.2°F to 446°F (-29°C to 230°C)
Graphite - 2 Anti-Extrusion Ring Graphoil
Temp. -20.2°F to 1050.8°F (-29°C to 566°C)

PACKING STUDS, NUTS & FOLLOWER:

300 Series Stainless Steel

GASKETS:

Body/Bonnet and Seat Ring/Body:
For up to 6" sizes: Spiral Wound 316L/Graphite
1000°F (+566°C) Max.
Above 6" sizes: Spiral Wound 316L/Graphite
449.6°F (232°C) Max.
Flexible Graphite, 1000°F (538°C) Max.

TRIM SIZES:

Full Port, 80%, 60%, and 40% Reduced Port.
Custom Cv: contact Application Engineering

PLUG (PISTON) SEAL MATERIALS:

C300 spring loaded seal with Inconel Spring -
Up to 572°F (300°C). Class IV or V
Double Carbon-Graphite seal rings - Up to
1000°F (538°C). Class IV

FLOW CHARACTERISTICS:

Equal Percentage, Linear

SHUTOFF CLASS (FCI / 70-2):

Standard trim, -20 to 572°F (-18 to 300°C) = Class V
to 800°F (427°C) - Class IV
High-temp trim, To 1000°F(538°C), Class IV

ACTUATORS:

Standard:
Multi-Spring and Diaphragm
Optional:
Piston, Double Acting/Spring Return
Hydraulic
Electric
Electro-Hydraulic

SIZING COEFFICIENTS

CASE TYPE	LIQUID		GAS
	F _L	K _C	X _T
Standard	.8	.65	.7
Les Cav	.9	.79	N/A
Les Sonic	N/A	N/A	.65

D-SERIES SPECIFICATIONS

D-SERIES Cv TABLE

Valve Size	Rating	Linear Full	=% ** Full	Les Sonic I	Les Sonic II	Les Cav I	Les Cav II
2(50)	150-1500	24	68	60	33	60	24
3(80)	150-1500	84	140	124	105	124	84
4(100)	150-1500	113	216	192	143	192	113
6(150)	150-1500	200	400	340	209	340	200
8(200)	150-600	336	756	672	330	672	336
8(200)	900-1500	302	680	604	297	604	302
10(250)	150-600	452	1100	816	528	816	452
12(300)	150-600	672	1440	924	798	924	672
16(400)	150-600	1047	2300	1785	1012	1785	1047

†Trim for Les Sonic II

** .8, .6, .4 factors available

MATERIAL SPECIFICATIONS

(Other Options - See Page 6)

“D” SERIES Material Specification - Standard, Balanced, Normal Temp

Item	Description	Material	Material Specification
1	Body/Bonnet	Carbon Steel	ASTM A216 GR WCC
2	Valve Plug	Stainless Steel	ASTM A487 GR CA 15 W/PTFE C300 spring loaded seal
3	Valve Stem	Stainless Steel	ASTM A479 TY 316
4	¼" NPT, Hex Head, Plug in Bonnet	Carbon Steel	ASTM A105
5	SWG Gasket - Body Bonnet	Graphite / Stainless Steel	GRAPHITE + AISI 316L
6	SWG Gasket - Seat Ring	Graphite / Stainless Steel	GRAPHITE + AISI 316L
7	Stud - Body / Bonnet	Alloy Steel	ASTM A193 GR B7
8	Heavy Hex Nut - Body / Bonnet	Steel	ASTM A194 GR 2H
9	Cage	Stainless Steel	ASTM A351 CF8M
10	Seat Ring	Stainless Steel	ASTM A351 CF8M
11	Packing Ring	PTFE / Stainless Steel	Live Loaded PRFE V-Ring w/304 Stainless Steel Spring
12	Guide Bush in Bonnet	Stainless Steel	ASTM A276 TY 440C
13	Packing Follower	Stainless Steel	ASTM A479 TY 304
14	Packing Flange	Carbon Steel	ASTM A36, Zinc plated, Yellow passivation
15	Stud Packing	Stainless Steel	ASTM A193 GR B8
16	Hex Nut - Packing	Stainless Steel	ASTM A194 GR 8
17	Lock Nut Actuator	Carbon Steel	ASTM A36, Zinc plated, Yellow passivation
18	Plug Pin	Stainless Steel	ASTM A479 TY 316
19	Jam Nut	Stainless Steel	ASTM A194 GR 8
20	Seal Ring	PTFE / Optional Graphite	PTFE + 25% CARBON GRAPHITE + FLUOROLOY/ CARBON-GRAPHITE C300 spring loaded seal

NOTE: Common to all trim modules including Les-Cav/Les -Sonic unless otherwise listed

INCONEL® is a trademark of the Inco Family of Companies

NITRONIC 60® is a trademark of Armco, Inc.

STELLITE® is a trademark of Stoodly Deloro Stellite, Inc.

NACE Material available upon request

D-SERIES ORDER CODE (Rev. 6)

Class	Body Style	Valve Size	Valve Rating	End Conn.	Bonnet Packing	Trim Mat'l	Cage Type	Rated Cv	Actuator Type	Actuator Spring	Leakage Class	Accessories	Compliance		
D	A	1	1	A	1	A	A	1	A	0	A	C	E	C	E
1	2	3	0	5	6	7	8	9	10	11	12	13	14	15	16

LINEAR

<p>Class - Position 1* D or M</p>
<p>Body Style - Position 2 A = Globe - WCC B = Globe - WC9 C = Globe - CF8M D = Globe - LCC E = Angle - WCC F = Angle - WC9 G = Angle - CF8M H = Angle - LCC</p>
<p>Valve Size - Position 3 1 = 2" 6 = 8" 2 = 2 1/2" 7 = 10" 3 = 3" 8 = 12" 4 = 4" 9 = 16" 5 = 6"</p>
<p>Valve Rating - Position 4 0 = ANSI 150 3 = ANSI 300 6 = ANSI 600 9 = ANSI 900 1 = ANSI 1500</p>
<p>End Connection - Position 5 A = RF Flange B = RTJ C = BWE 40 D = BWE 60 E = BWE 80 F = BWE XS G = BWE XXS H = SWE 40 I = SWE 60 J = SWE 80 K = SWE XS L = SWE XS M = SWE XXS N = THD X = Other</p>
<p>Bonnet & Packing - Position 6 1 = Std.-PTFE 2 = Std.-Graph 3 = Std.-DBL PTFE 4 = Std.-DBL Graph 5 = Ext.-PTFE 6 = Ext.-Graph 7 = Ext.-DBL PTFE 8 = Ext.-DBL Graph</p>
<p>Trim Material - Position 7 A = Std. (410 SST) w/C300 spring loaded seal B = 316 SST w/C300 spring loaded seal C = 316/STELL w/ C300 spring loaded seal D = STD (410 SST) w/Graph-Seal E = 316 SST w/Graph-Seal F = 316/STELL w/Graph-Seal G = CA6NM w/Graph-Seal (HT) N = NACE (316 SST w/C300 spring loaded seal)</p>

<p>Cage Type - Position 8 A = STD - LIN (Flow over seat) B = STD - EQQ (Flow over seat) C = LES-CAV I (Flow over seat) D = LES-CAV II (Flow over seat) E = LES-Sonic I (Flow under seat) F = LES-Sonic II (Flow under seat)</p>
<p>Rated Cv - Position 9 1 = 100% 8 = 80% 6 = 60% 4 = 40%</p>
<p>Actuator Type - Position 10 & 11 A0 = M42-D A1 = M42-R A2 = M82-D A3 = M82-R A4 = M155-D A5 = M155-R B0 = M42-D-HOD B1 = M42-R-HOD B2 = M82-D-HOD B3 = M82-R-HOD B4 = M155-D-HOD B5 = M155-R-HOD C0 = S55-D C1 = S55-R C2 = S85-D C3 = S85-R C4 = S135-D C5 = S135-R D0 = S55-D-HOD D1 = S55-R-HOD D2 = S85-D-HOD D3 = S85-R-HOD D4 = S135-D-HOD D5 = S135-R-HOD E0 = P25-DA-D E1 = P25-DA-R E2 = P25-DASR-D E3 = P25-DASR-R E4 = P25-SASR-D E5 = P25-SASR-R F0 = P25-DA-D-HOD F1 = P25-DA-R-HOD F2 = P25-DASR-D-HOD F3 = P25-DASR-R-HOD F4 = P25-SASR-D-HOD F5 = P25-SASR-R-HOD G0 = P50-DA-D G1 = P50-DA-R G2 = P50-DASR-D G3 = P50-DASR-R G4 = P50-SASR-D G5 = P50-SASR-R H0 = P50-DA-D-HOD H1 = P50-DA-R-HOD H2 = P50-DASR-D-HOD H3 = P50-DASR-R-HOD H4 = P50-SASR-D-HOD H5 = P50-SASR-R-HOD J0 = P75-DA-D J1 = P75-DA-R J2 = P75-DASR-D</p>

<p>J3 = P75-DASR-R J4 = P75-SASR-D J5 = P75-SASR-R K0 = P75-DA-D-HOD K1 = P75-DA-R-HOD K2 = P75-DASR-D-HOD K3 = P75-DASR-R-HOD K4 = P75-SASR-D-HOD K5 = P75-SASR-R-HOD L0 = P150-DA-D L1 = P150-DA-R L2 = P150-DASR-D L3 = P150-DASR-R L4 = P150-SASR-D L5 = P150-SASR-R M0 = P150-DA-D-HOD M1 = P150-DA-R-HOD M2 = P150-DASR-D-HOD M3 = P150-DASR-R-HOD M4 = P150-SASR-D-HOD M5 = P150-SASR-R-HOD N0 = P200-DA-D N1 = P200-DA-R N2 = P200-DASR-D N3 = P200-DASR-R N4 = P200-SASR-D N5 = P200-SASR-R P0 = P200-DA-D-HOD P1 = P200-DA-R-HOD P2 = P200-DASR-D-HOD P3 = P200-DASR-R-HOD P4 = P200-SASR-D-HOD P5 = P200-SASR-R-HOD XX = OTHER ZZ = NONE (MBSA)</p>
<p>Actuator Spring - Position 12 A = 3 - 15 (B6 - 2G) B = 12 - 45 (B6 - 6G) C = 12 - 40 (A6 - 6G) D = 4 - 20 (C6 - 3G) E = 10 - 45 (C6 - 7G) G = 10 - 30 (B6 - 3D) H = 17 - 50 (B6 - 5D) J = 23 - 70 (B6 - 7D) K = 12 - 30 (C6 - 3D) L = 20 - 50 (C6 - 7D) M = 28 - 68 (C6 - 7D) N = 3-15 psig (piston) P = 6-30 psig (piston) R = 11-23 psig (piston) S = 21-45 psig (piston) X = NONE Z = SEE ORDER</p>
<p>Leakage Class - Position 13 4 = Class IV 5 = Class V</p>
<p>No of Accessories - Position 14 No Accessories 1 = Accessory 2 = Accessories 3 = Accessories 4 = Accessories 5 = Accessories 6 = Accessories 7 = Accessories 8 = Accessories 9 = Accessories A = 760P (Only) B = 760E (Only) C = PS2 (Only) D = 760P + ASG-1 E = 760E + ASG-1 F = PS2 + ASG-1</p>
<p>Compliance - Position 15 & 16 NONE CE = CE CERT. NE = NACE</p>

*Use D for Leslie/RTK Product Brands and M for Mallard Product Brand

	= Phase II release (not currently in Circor Select®)
	= TBD whether this will be released at all on D-Series
760P	= Leslie P/N A79104 (760P11AAAGNND6 - FM/CSA/ATEX/CE, NO LIMIT SWITCHES, NO FEEDBACK, SGL/DBL ACTING, 1/2" - 4" STK)
760E	= Leslie P/N A79105 (760E11AAAGNND6 - FM/CSA/ATEX/CE, NO LIMIT SWITCHES, NO FEEDBACK, SGL/DBL ACTING, 1/2" - 4" STK)
PS2	= Leslie P/N A87015 (6DR52200EN000AA4 - HART/EEEx ia/ib (CEN-ELEC /ATEX/FM/CSA), NO LIMIT SWITCHES, NO FEEDBACK. DBL ACTING 1.3" - 5" STK)
AASG-1	= Leslie P/N a801072 (0 - 100 psig)



D-SERIES APPLICATIONS

Applications

FEEDWATER CONTROL regulates level of water in boiler drum. A 1 - 3 drum design is commonly based on HP, IP & LP applications. Valve receives water flow from pump and supplies water to drum to make up for that used to produce steam.

FEEDWATER RECIRCULATION valve insures that adequate flow is maintained through feedwater pump. The pump manufacturer calculates minimum flow required to prevent risk of premature pump failure due to bearings overheating or excessive thermal expansion of impeller blades.

AUXILIARY STEAM PRESSURE REDUCTION

- 1) Soot Blowers increase thermal efficiencies. Valve controls steam supplied to header from super heated source. PRV sees high pressure drop, intermittent operation, and rapid load swings.
- 2) Building Heat, extraction steam control.
- 3) Pegging, Deaerators use super heated steam to heat and remove air from condensate. Normally closed against high differential pressure.

GLAND SEAL STEAM, valves are used to maintain constant steam pressure in gland to seal air from turbine. Application requires HP steam, throttling a low flow at high DP. Typically these valves operate in a split range mode. One pressure signal either loads or vents the gland.

ATTEMPERATOR SPRAY, SUPERHEAT, REHEAT - Spray Control valve, is used for controlling steam temperature to turbine. The purpose of valve is to maintain a tight temperature band resulting in maximum efficiency.

- 1) Superheat spray, low DP, turndown, and accuracy are important.
- 2) Reheat spray, high DP, with Cavitation and seat leakage concerns as the valve operates close to the seat.

D-SERIES - LINEAR VALVE SPECIFICATION FORM

LINEAR

 CONTROL VALVE SPEC SHEET	Project/Job _____	Data Sheet _____ of _____
	Unit/Customer _____	Spec _____
	P.O./LCO File # _____	Tag _____
	Item _____	Dwg _____
	Contract _____	Service _____
MFR Serial# _____		

Fluid Steam Water Gas _____ Liquid _____ Crit Pres PC

Service Conditions	Max. Flow	Norm. Flow	Min. Flow	Shut-off Pressure
Flow <input type="checkbox"/> #/hr <input type="checkbox"/> gpm <input type="checkbox"/> scfh <input type="checkbox"/> _____				
Inlet Pressure <input type="checkbox"/> psig <input type="checkbox"/> psia <input type="checkbox"/> _____				
Outlet Pressure <input type="checkbox"/> psig <input type="checkbox"/> psia <input type="checkbox"/> _____				
Temperature <input type="checkbox"/> °C <input type="checkbox"/> °F _____				
Max Press/Temperature: _____ / _____				
Density/MW/SG _____ / _____ / _____				
Viscosity _____ CP				
Vapor Pressure <input type="checkbox"/> psia <input type="checkbox"/> _____				
Required C _v _____ Noise (dBA) Allowable _____				

Line Info Pipe Size In _____ /Sch _____ Pipe Size Out _____ /Sch _____

Valve, Body & Bonnet

Body Size in. 2 2½ 3 4 6 8 10 12 16

ANSI Class 150 250 300 600 900 1500 Other _____

Body/Bonnet Material: Cast Steel WCC Cr MoC9 SS A351 CF8M _____ Other _____

End Conn. Inlet/Outlet: NPT SWE BWE Sch. _____ Int. Flanges RTJ Other _____

Packing Material: PTFE Laminated Graphite Other _____

Trim Size 100% 80% 60% 40% Les-Cav I Les-Cav II Les-sonic I Les-sonic II Other _____

Actuator

Spring Action: Air to Open Air to Close Last Position Other _____ None

Available Air Supply Pressure: Max. _____ Min. _____ Other _____

Manual Override: Yes No Type _____ ***Accessory Classification NEMA 4D, 7D, 9D** Other _____

Solenoid Yes No Type _____ Voltage _____

***Positioner** Yes No Type _____ Pneu E/P Digital Protocol _____

***Switch** Yes No Type _____ Voltage _____ Classification _____

Air Set Yes No Type: _____ Range: _____ Gage Y N

Other Accessories Yes No Type _____

Test ANSI/FCI Leakage Class: III IV V VI

*Specify Protocol HART / FFB / Profi, etc.

NOTES:

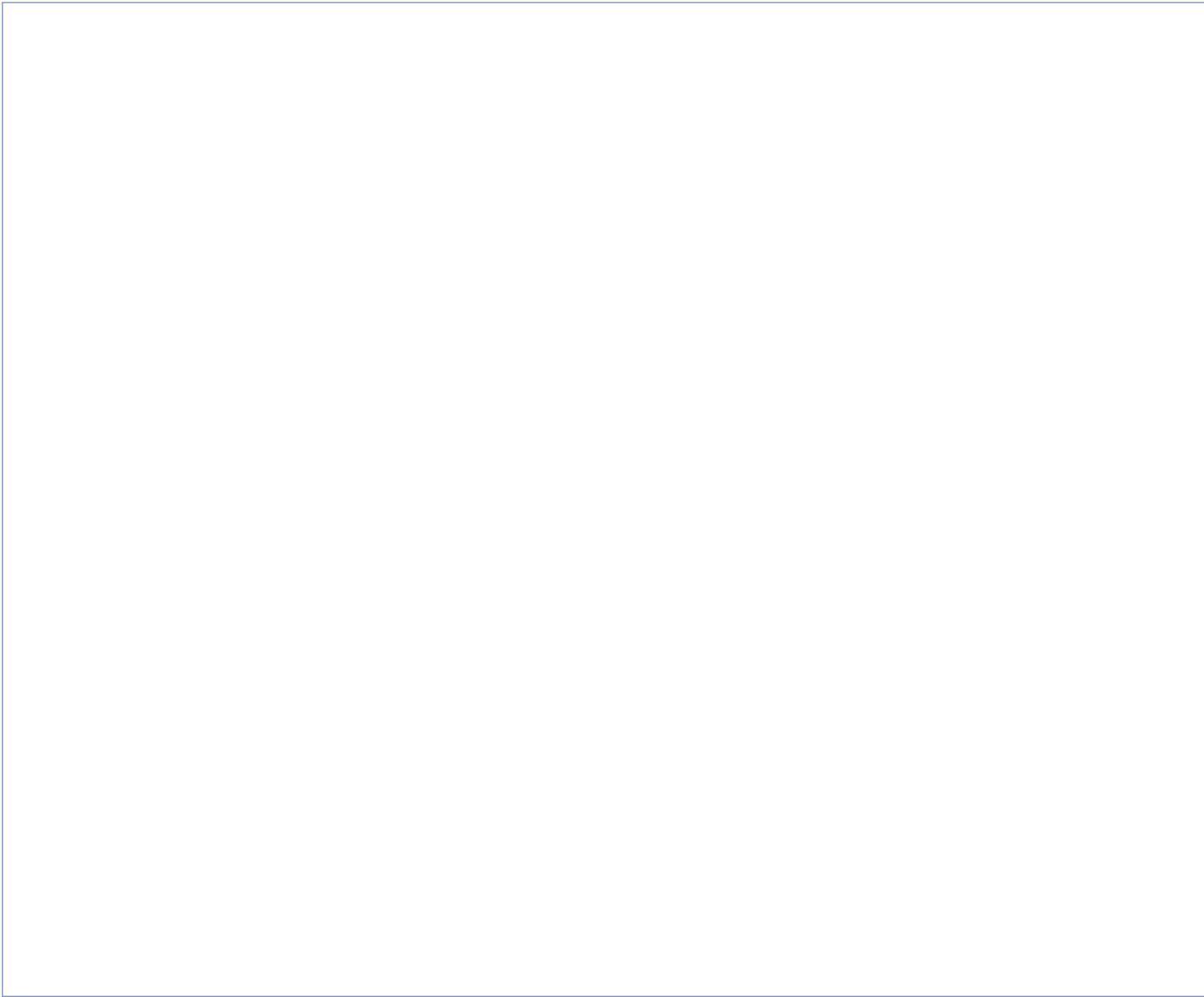
A large, empty rectangular box with a thin blue border, intended for taking notes. It occupies most of the page's width and height.