

# FCCU REACTOR - FRACTIONATOR ISOLATION VALVE

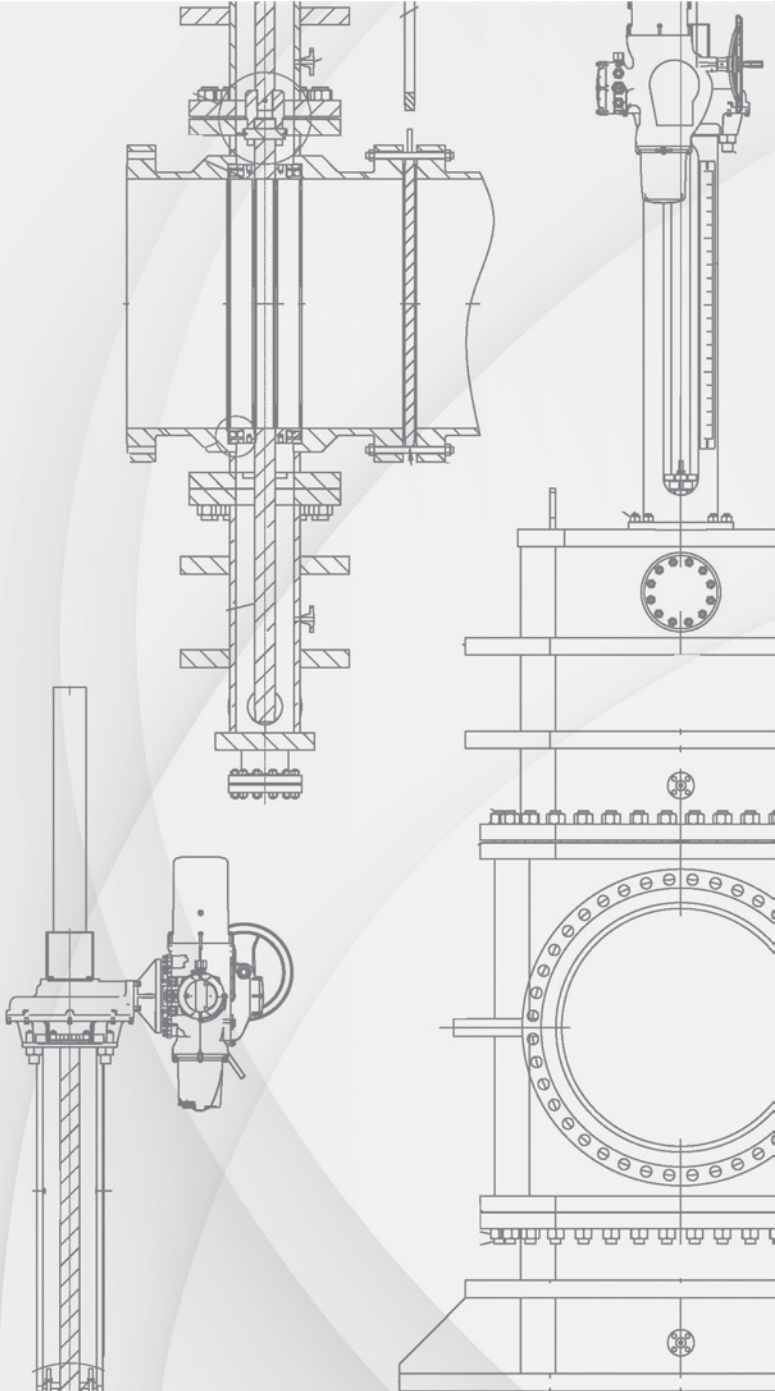

TapcoEnpro

## THE CHALLENGE

An FCCU is expected to operate without interruption for 3 to 6 years. Maintenance requirements include isolating the reactor from the fractionator by placing a physical blind in the reactor overhead line. The manual insertion and removal of the blind flange is one of the most threatening operations in the refinery. There is a need for a safe operator environment for isolation of a hazardous process by eliminating personnel from the operation and emissions of hydrocarbons to the atmosphere.

## THE SOLUTION

TapcoEnpro's Isolation Valve provides a safer environment during the manual installation of the physical blind by allowing automated isolation of the reactor from the fractionator resulting in safer FCCU unit operations.

- Increased durability and reliability through the valve's simplicity of design
- Allows for shorter restart times and faster, more efficient shutdowns
- Tight sealing against particulate migration into the valve body in both open and closed positions

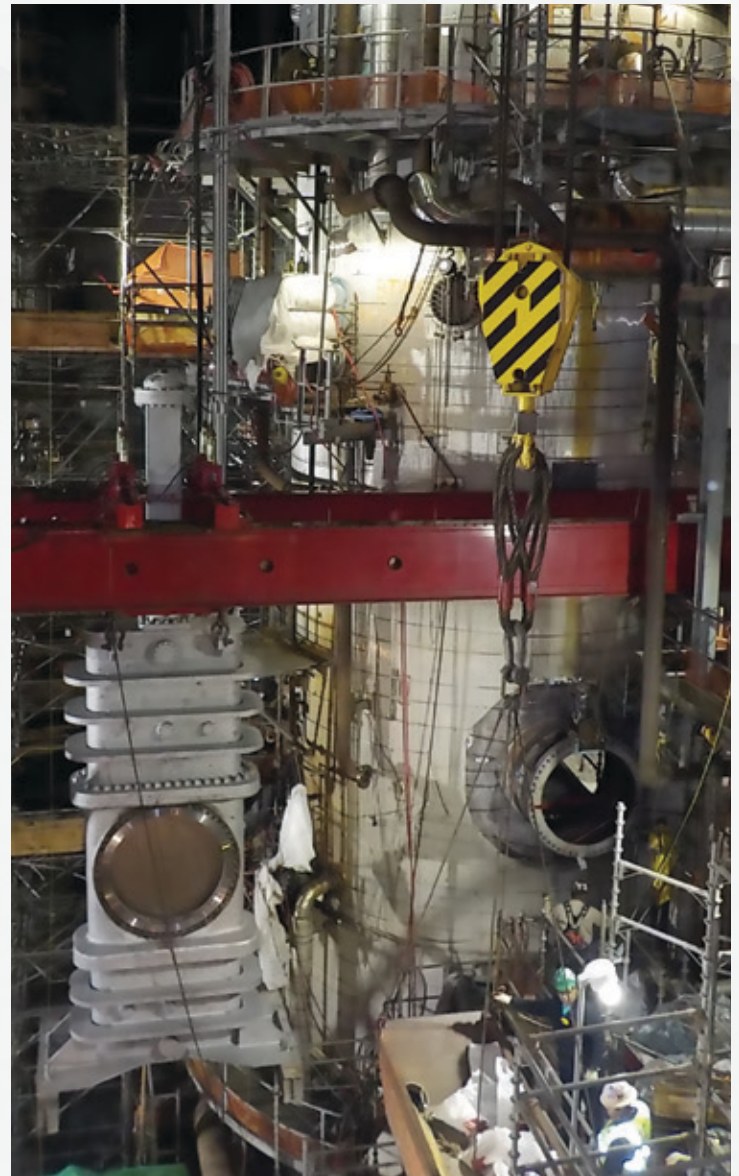

- Allows for quick isolation of the reactor from the fractionator in the event of a unit upset or emergency shutdown due to unanticipated events.
- Low utility consumption provides lower cost of ownership

## INDUSTRY CHALLENGES TO SOLVE

- Volatile and Hazardous emissions released to atmosphere during blind installation
- Hazardous work environment for operators installing the fractionator isolation blind
- Time consuming blind installation leads to costly added time in unit outages to shutdown and start-up

## INDUSTRY CHALLENGES WE SOLVED

- Provides greater opportunity for safe isolation of vessels
- 100% process isolation with Double Block and Purge technology
- Simple, robust and reliable design with a single moving component
- True mechanical gate position indication and positive lockout mechanism
- Engineered specifically for the reactor overhead line operational conditions and sizes
- Low maintenance costs

Numerous Actuation Options

Live-Loaded Packing Gland

Purged Body and Bonnets Prevent Contaminate Migration

Bi-Directional Flow Control

Top Entry, In-Line Serviceable

Multiple Steam Purge Ports to Provide Installation Flexibility

Double Block and Purge

Ultra-Tight, Double Live-Loaded Self-Cleaning Seats

Reverse Gate Design

## OUR SOLUTIONS

- Gate is in a safe down-seated position while open and regardless of upset conditions or equipment failure, the gate remains static and will not close
- Ultra-low steam consumption

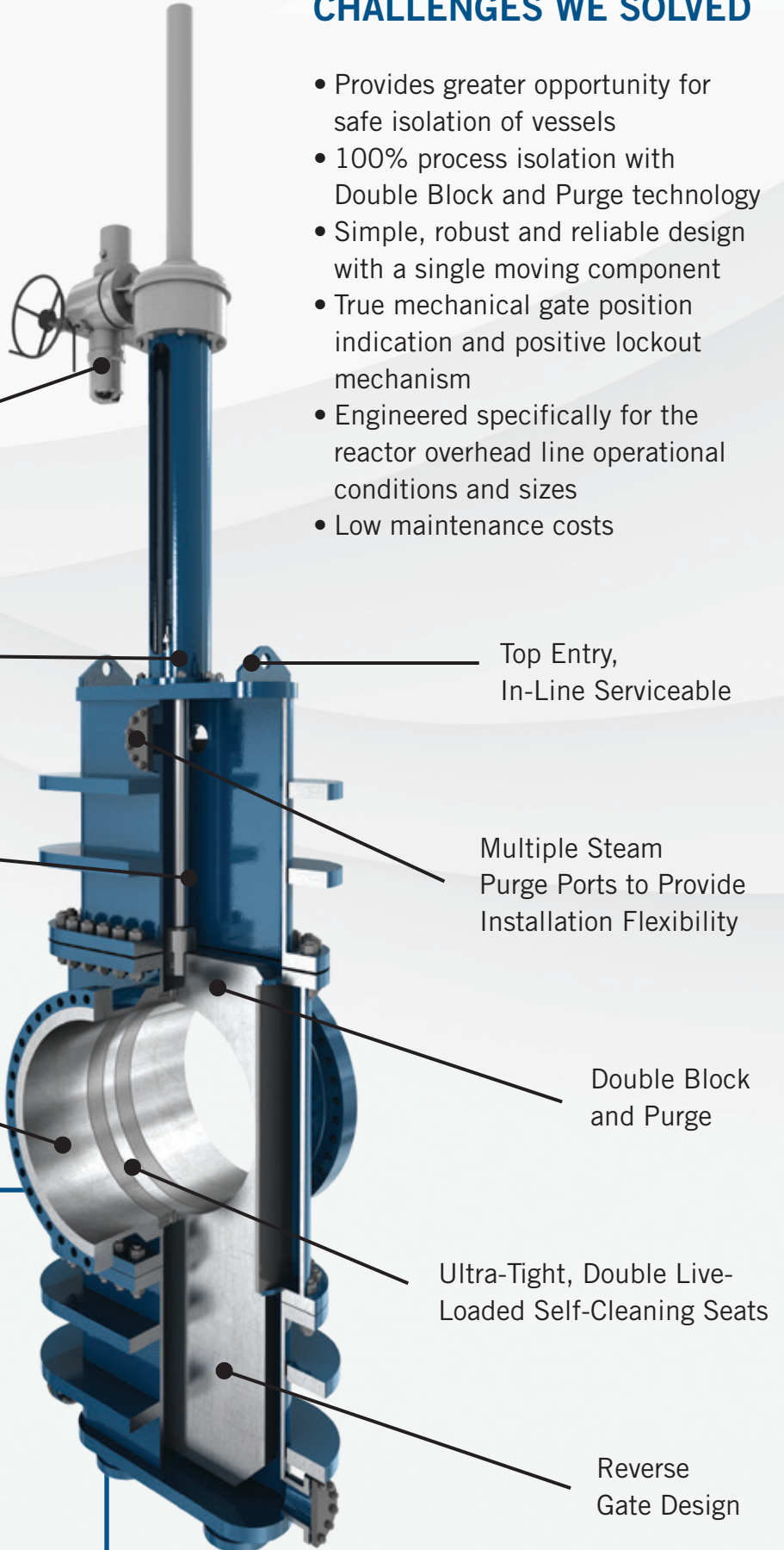



For over 70 years, TapcoEnpro has been the world leader in the design and manufacture of critical service valves, equipment and services for Fluid Catalytic Cracking (FCC) Units.

We offer a full range of products including:

- Hot and Cold Shell Slide Valves
- Spent and Regen Plug Valves
- Hydraulic Power / Control Units
- Flue Gas Butterfly Valves
- PLC / Digital Controllers
- Expander Butterfly Valves
- Flue Gas Diverter Valves
- Hydraulic Actuators
- Catalyst Withdrawal Valves
- Flue Gas Isolation Valves

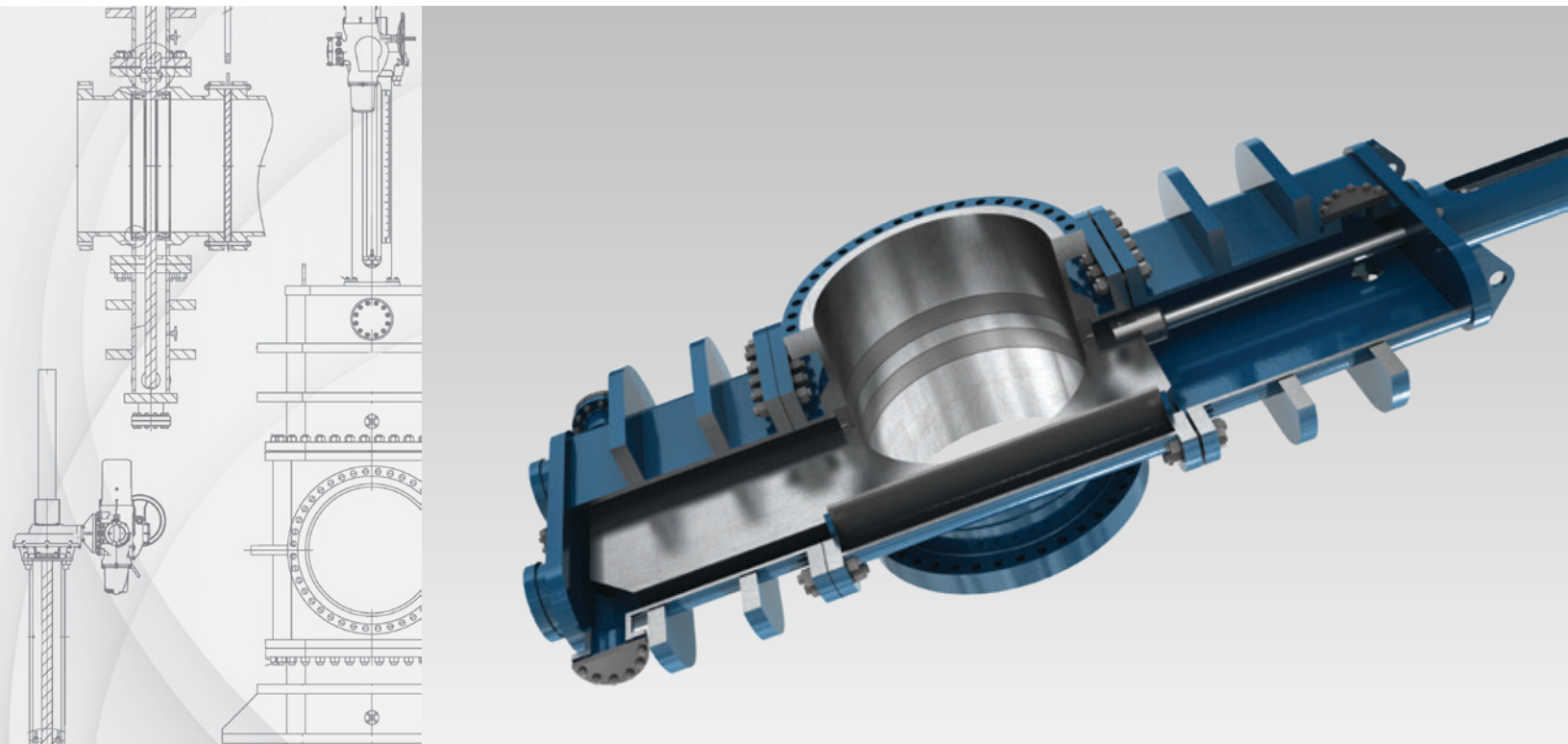

**Corporate Office, Manufacturing and Service Center**

16315 Market Street  
Channelview, Texas USA  
Phone: +1.281.247.8100

**UK Manufacturing and Service Center**

Shawfield Road, Carlton Industrial Estates Barnsley S71 3HS  
United Kingdom  
Phone: +44.1226.323.160

**India Manufacturing and Service Center**

SF No. 337/2, No.15 Naranapuram Village  
Ponnandampalayam, Coimbatore, Tamil Nadu 641659, India  
Phone: +91.421.232.1600

EMAIL: [TAPCOENPRO@CIRCOR.COM](mailto:TAPCOENPRO@CIRCOR.COM)