

SR800 Series

*High Capacity Pressure Regulator
Inlet to 3,600 psig & Outlet to 250 psig*



Features

- High flow rates of 1.65 Cv
- Diaphragm provides maximum sensitivity
- Pressure relief valve for safety protection
- Panel mounting standard
- Wide range of fluid compatibility
- Balanced Poppet

Applications

- Manifold pressure control
- Process gas control
- Blanket or purge gas control
- High flow station or main line controls

Technical Data

Body Construction Material	Bronze forging
Seat Material	Nylatron® GS (standard)*
Seal & Diaphragm Material	Neoprene (standard)*
Spring Material	Steel
Spring Housing Material	Brass
Port Size	½" NPT female
Pressure Ratings	Inlet: 3,600 psig (248 BAR) Outlet: • SR800: 250 psig (17 BAR) max. • SR830: 125 psig (8.6 BAR) max.
Temperature Range	-60° F to +160° F (-51° C to +71° C)
Flow Capacity	Cv = 1.65 max. Orifice diameter = 0.30"

* See "How to Order" for optional materials
Outlet pressure rise per 100 psi inlet pressure decay ¼ psi max.

How it Works

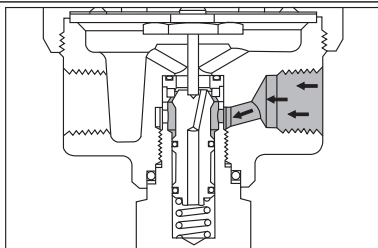

Closed

Balanced poppet is spring-loaded against the seat. When full upstream pressure is applied, a slightly unbalanced force is developed which enhances sealing.

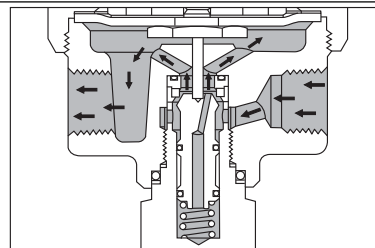

Regulating

As the downstream process demands flow, the pressure acting on the bottom of the diaphragm decays, allowing the adjusting spring force to push the poppet down. This in turn unseats the poppet, allowing flow to begin and pressure under the diaphragm to increase until balance is achieved between adjusting spring force and downstream pressure. This condition continues until process demand ceases. At this point, increasing pressure overcomes the spring force, moving the diaphragm up and allowing the poppet to close.

Circle Seal Controls

2301 Wardlow Circle • Corona, CA 92880
Phone (951) 270-6200 • Fax (951) 270-6201
www.circlesealcontrols.com

SR800 Series

Dimensions & Flow Curves

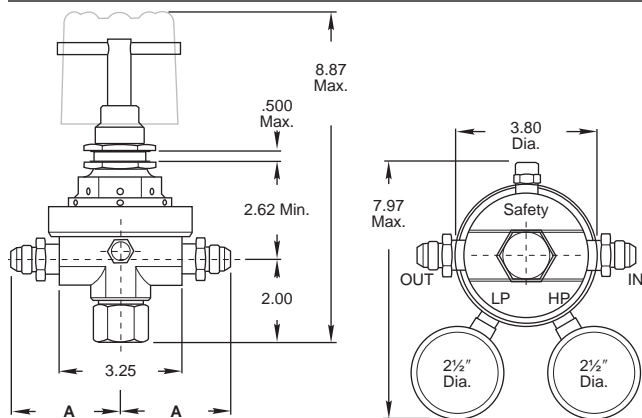

Typical Flow Curve

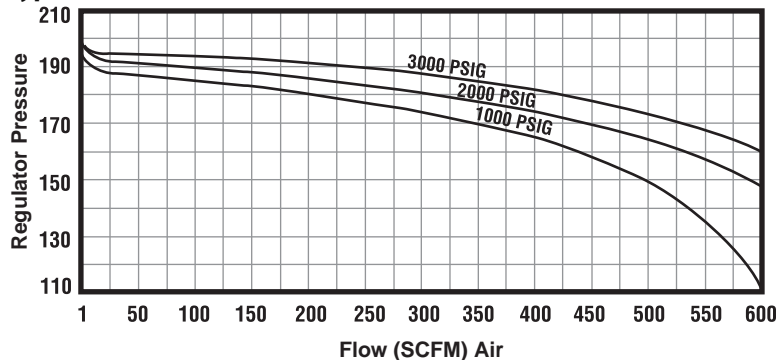

Inlet Connections

Part No.	Connection	A
-1	MS33656-8	2 ² / ₃ "
-2	MS33656-12	3 ³ / ₄ "
-3	1/2" NPT female	1 ¹ / ₂ "
-xxx	CGA fitting	—

Pressure Range

Gauge Ranges		Safety Valve Set
Inlet	Outlet	Pressure
0-5,000 psig	0-600 psig	400 psig
0-5,000 psig	0-200 psig	200 psig

How to Order

K/ SR800 B 3 3 1 1 2 G

REPAIR KIT

BASIC MODEL NUMBER & OUTLET PRESSURE RANGE

- SR800** 0 to 250 psig (0 to 17 BAR)
- SR830** 0 to 125 psig (0 to 9 BAR)

BODY MATERIAL

- B** Bronze forging

INLET CONNECTION

- 1** MS33656-8
- 2** MS33656-12
- 3** 1/2" NPT female
- xxx** Insert CGA number (example: 580)

OUTLET CONNECTION

- 1** MS33656-8
- 2** MS33656-12
- 3** 1/2" NPT female

OPTIONS

- G** Pressure gauges, brass
- B** Bell handle
- L** Hex head adjustable screw with lock nut

CLEANING LEVELS*

- 1** For general oxygen service
- 2** For general pneumatic service
- 3** Specify (define on sales order)
- 4** For precision pneumatic service

SEAT MATERIAL

- 1** Nylatron® GS (standard)
- 2** Kel-F® (3,000 psig max.)
- 4** KYNAR®
- 5** Polyimide (Vespel® SP-21)
- 6** Polyurethane

SEAL & DIAPHRAGM MATERIAL

- 1** Neoprene (standard)
- 3** Viton®
- 4** Buna N
- 5** PTFE seal, PTFE-coated neoprene diaphragm

* If this regulator is to be used in oxygen service, specify "GENERAL OXYGEN SERVICE" when ordering or furnish the factory a copy of the special requirements. Vespel® SP-21 or Kel-F® seat, Viton® diaphragm and seals. Temperature range: -20° F to +250° F.

Note: Proper filtration is recommended to prevent damage to sealing surfaces.

Please consult your Circle Seal Controls distributor, representative, or the factory for information on special connections, operating pressures and temperature ranges.

For Your Safety

It is solely the responsibility of the system designer and user to select products suitable for their specific application requirements and to ensure proper installation, operation, and maintenance of these products. Material compatibility, product ratings and application details should be considered in the selection. Improper selection or use of products described herein can cause personal injury or property damage.

Nylatron® is a registered trademark of DSM Engineering Plastic Products.
 Kel-F® is a registered trademark of 3M Company.
 KYNAR® is a registered trademark of ATOFINA Chemicals, Inc.
 Vespel® is a registered trademark of E.I. du Pont de Nemours and Company.
 Viton® is a registered trademark of DuPont Dow Elastomers.