

Hole pattern of pump foot

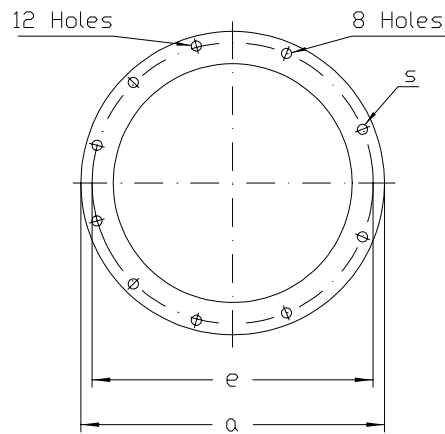

Approximate Dimensions
 Dimensions not to be used for construction purposes

211.10 Pumpsize	Suction PN16	Disch. PN16	Motor		
			kw	rpm	Frame
118	150	100	55	1480	250M
135	200	150	90	1480	280M
150	250	200	110	1480	315S
165	250	200	160	1480	315M
180	300	250	200	1480	315L
210	350	300	250	1480	355M

211.10 Pumpsize	a	c	e	E	g	i	j	o1	o2	p	s	v	w	x	z
118	540	25	500	42	260	230	265	520	545	615	8x18	140	375	735	1725
135	565	25	525	47	280	245	332	560	585	680	8x18	140	390	920	1990
150	620	30	570	52.5	300	255	345	600	625	750	8x22	170	430	955	2135
165	650	30	600	57.5	315	285	395	630	655	780	8x22	170	460	1055	2295
180	690	35	640	63	335	290	410	630	655	805	12x22	170	465	1125	2395
210	850	40	800	73.5	450	335	600	700	725	905	12x22	210	550	1230	2685

