

Sectoinal drawing 231.50

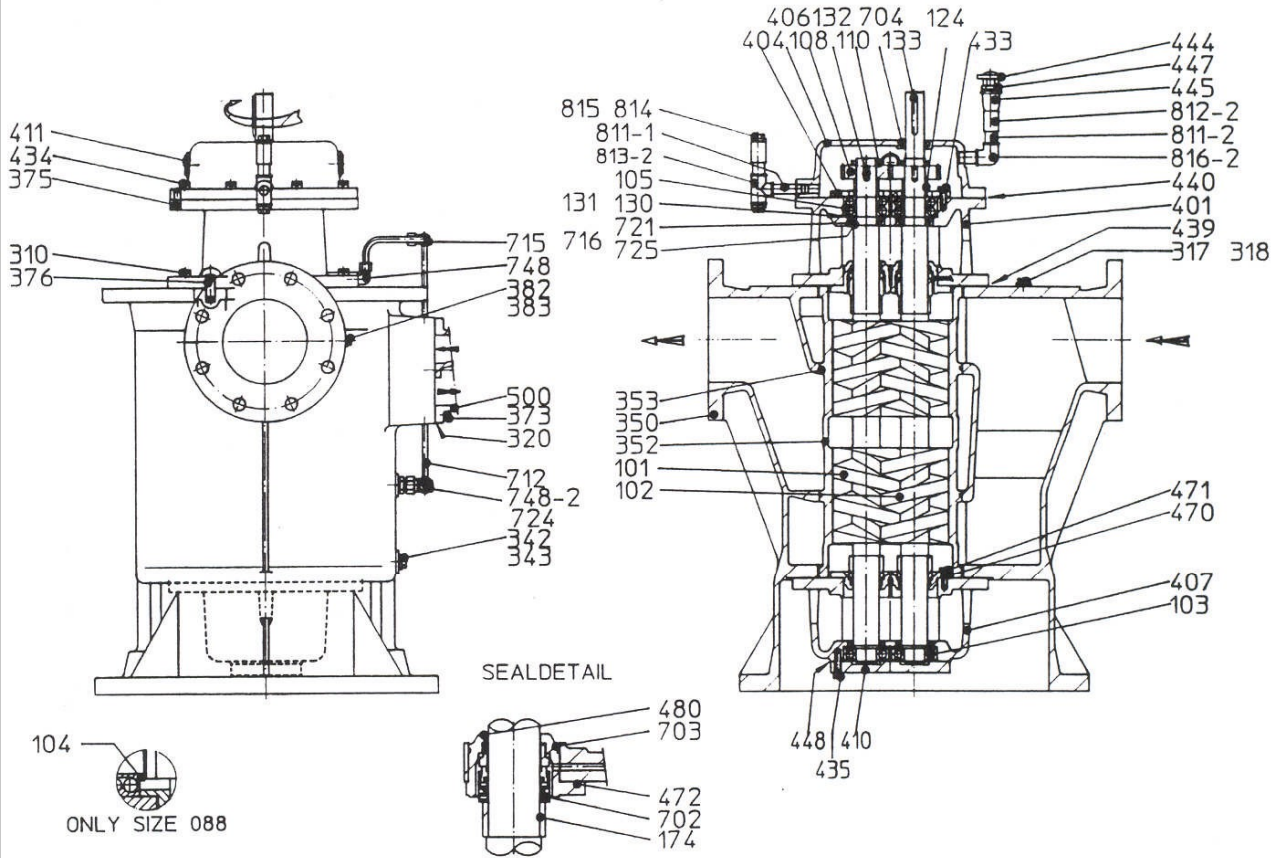

Part No. Description

| | |
|-----|-------------------------|
| 101 | Short screw shaft |
| 102 | Long screw shaft |
| 103 | Single row ball bearing |
| 104 | Support ring |
| 105 | Double row ball bearing |
| 108 | Gear wheel |
| 110 | Nut |
| 124 | Distance bush |
| 130 | Shim 0,1 mm |
| 131 | Shim 0,05 mm |
| 132 | Key |
| 133 | Key |
| 174 | Support ring |
| 310 | Socket screw |
| 317 | Filler cap |
| 318 | Joint washer |
| 320 | Gasket |
| 342 | Socket screw |
| 343 | Joint washer |
| 350 | Pump casing |
| 352 | Cylinder liner |
| 353 | O-ring |
| 373 | Socket screw |
| 375 | Fitted pin |
| 376 | Fitted pin |
| 382 | Filler cap |
| 383 | Joint washer |

Part No. Description

| | |
|-----|---------------------------|
| 401 | Cover |
| 404 | Ball bearing cover |
| 406 | Gearbox |
| 407 | Cover |
| 410 | Ball bearing cover |
| 411 | Oil-level indicator |
| 433 | Tapbolt |
| 434 | Socket screw |
| 435 | Socket screw |
| 439 | Gasket |
| 440 | Gasket |
| 444 | Breather |
| 445 | Reducing socket |
| 447 | Reducing ring |
| 448 | Gasket |
| 470 | Seal cover |
| 471 | Tapbolt |
| 480 | Anti-rotation pin for 702 |

Part No. Description

| | |
|-------|---------------------|
| 702 | Mechanical seal |
| 703 | O-ring |
| 704 | Lip-seal |
| 712 | Pipe |
| 715 | T-coupling |
| 716 | Orifice |
| 721 | Lip-seal |
| 722 | Adjustable coupling |
| 724 | Reducing coupling |
| 725 | Bush |
| 748 | Coupling |
| 748-2 | Coupling |
| 811-1 | Pipe |
| 811-2 | Pipe |
| 812-2 | T-socket |
| 813-2 | Reducing socket |
| 814 | Filler cap |
| 815 | Joint washer |
| 816-2 | Coupling |