



AEROFLOW SUPPLEMENT

Special “Upseating Mini-P” Actuator Adjustment

TABLE OF CONTENTS

INSTALLATION1

MAINTENANCE2

ILLUSTRATION INDEX

FIGURE 1 – VALVE ASSEMBLY SHOWN IN OPEN POSITION 2

INSTALLATION

CAUTION!

All warnings from valve IOM must be followed.

CAUTION!

Keep all extremities away from moving parts on the actuator. Failure to do so may cause injury or even death.

NOTE: Refer to Fig. 1 for installation.

1. Slide the seat-ring over the plug stem (1) and lower the assembly down into the valve body with the seat ring gasket (follow valve IOM for assembly of valve). *Note: Do not allow the valve plug to slam into the bottom of the valve. Lower the valve stem slowly until it comes to rest.*
2. Disassemble the stem coupling (3) cap screws.
3. Mount the actuator to the top of the valve.
4. With the actuator mounted to the valve, the actuator piston (5) will be in the “up” (retracted) position (no air in actuator).
5. Thread the stem coupling (3) all the way down onto the valve stem (1) . *The packing in the valve should be “loose” at this point to allow the valve plug to retract into the valve body.*
6. Ensure that the valve spring tensioner (4) is completely unadjusted.
7. By placing air to the top of the actuator stroke the actuator down 3.25” (air pressure not exceed 80 psi)
8. Pull up on the valve stem (1) and assemble the stem coupling (3), by tightening the coupling cap screws. The valve should now stroke about .75”. **(If this procedure is not followed, the valve stem can be driven down into the valve lower body and damage may occur to the valve body, trim or both.)**
9. The correct valve stroke for this trim set is 1”. Put 80 psig air to the top of the actuator, unscrew the valve stem (1) from the stem coupling (3) ¼ - 1 full turn at a time. After each adjustment stroke the valve until 1” stroke is obtained.
10. Tighten the valve locking nut (2). The spring tensioning nut (4) should not need to be

adjusted. *The bench set for the actuator should be approximately starting at 21 psig to start closing the valve (retracting stem) and ending at 26 psig when the valve is closed (actuator stem fully retracted).*

point of reference Fig. 1 shows the valve in the open position.)

MAINTENANCE

11. The valve is to have the limit switch mounted in the valve closed position. The valve is an upseating valve so the limit switch must be adjusted to activate when the piston actuator reaches the top of its stroke (fully retracts). (As a

1. The valve IOM should be followed for all operating and maintenance procedures.

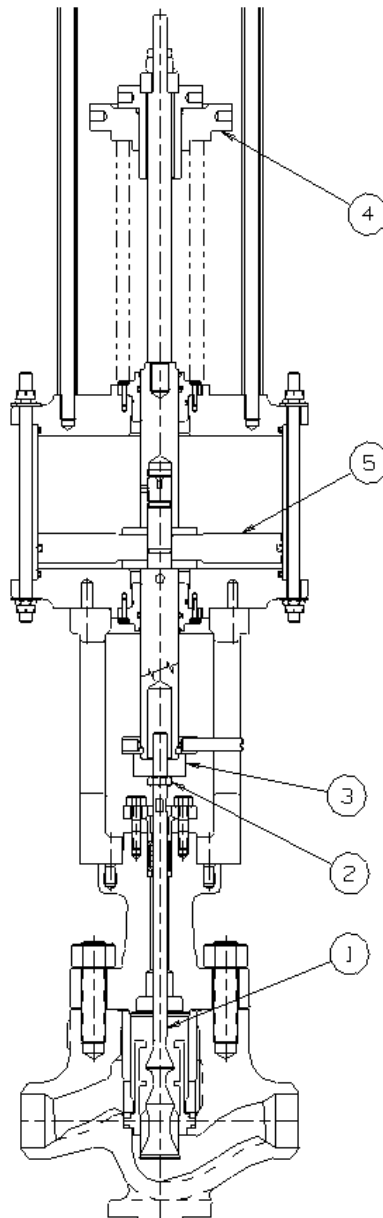

Figure 1 – Valve Assembly Shown in Open Position