

LPD Std Line

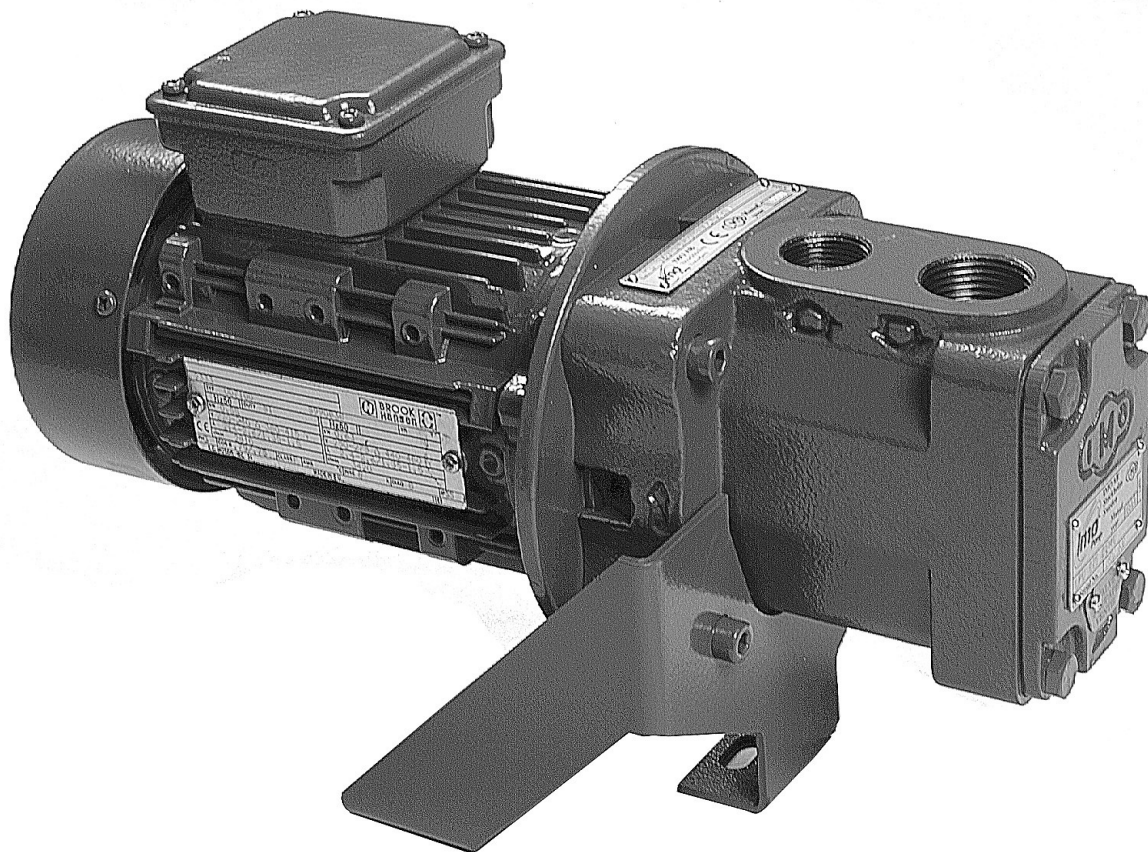

Product Description



Flow volume:	2 - 20 l/min
Max differential pressure:	10 bar
Applications:	Circulation and lubrication

1. Applications

1.1 Functionality

The LPD pumps are used for a number of different fluids: Lubrication oil, vegetable oil, hydraulic oil and other hydraulic fluids, polymers, emulsions and any non-aggressive fluid with sufficient lubricating properties.

1.2 Applications

Typical applications are:

- Lubrication of machines such as diesel engines, gears etc
- Supply and circulation of fuel oil for diesel engines, separators and burners

1.3 Installation

The pump is designed to be short coupled directly to an IEC 071 electric motor of flange type. By the angle bracket, the pump might be mounted horizontally or vertically.

As standard; the pump is supplied included counter flanges (IMO AB design).

For more information about installation, see the Installation and Start-up instruction for low pressure pumps.

2. Pump model code

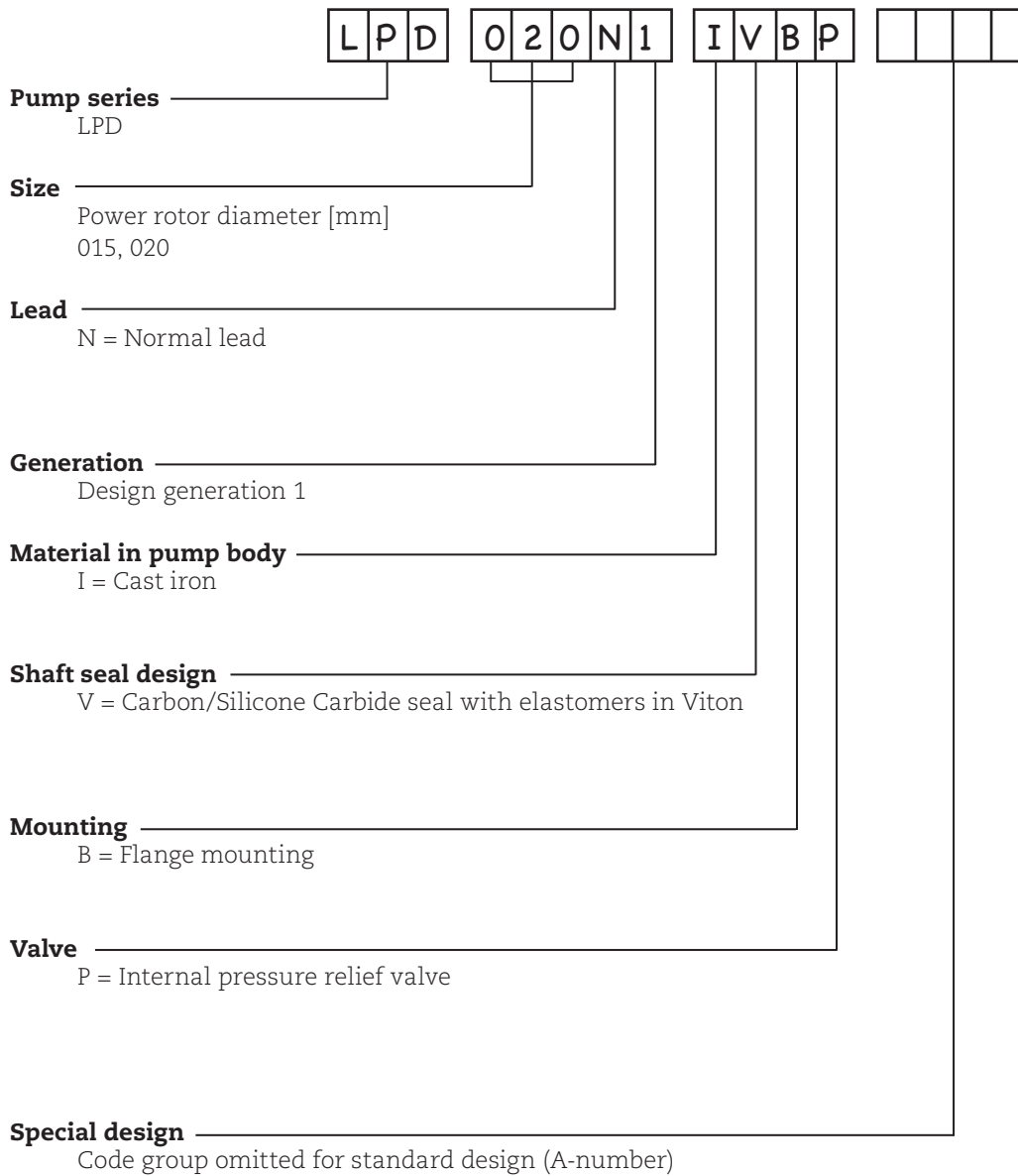

3. Technical Data

3.1 Pressure Information

Pressure relief valve

The pump is equipped with an integral pressure relief valve with internal return, limiting the differential pressure across the pump and protecting the pump.

Should the discharge line be blocked, the relief valve will be opened by the pressure.

The valve is adjustable for different opening pressures. The value of the pressure limit can be set at the factory and should be adjusted at installation (see Installation & Start-up instruction for low-pressure pumps).

The maximum pressure accumulation is 3 bar.

The valve has a maximum set pressure of 10 bar.

Inlet pressure

Minimum inlet pressure (suction capability) is dependent on fluid viscosity and rotation speed. It increases with decreasing viscosity and decreasing speed. Information about minimum inlet pressure for each individual duty case can be obtained from IMO AB or pump selection software WinPump.

For size 015, maximum inlet pressure is 1 bar.

For size 020, maximum inlet pressure is 5 bar.

For higher inlet pressure, kindly contact IMO AB.

Discharge pressure

For size 015, maximum discharge pressure is 11 bar.

For size 020, maximum discharge pressure is 15 bar.

Differential pressure

Maximum differential pressure is 10 bar but reduced at low viscosities according to table below

Viscosity [cSt]	1,4	2	6	10	>16
Max. diff. pressure [bar]	3,4	4,0	6,5	8,3	10

Refer to your IMO representative or use the pump selection software WinPump to determine the exact operating limits.

3.2 Driver information

Driver type

The pump is designed to be short-coupled to an electric motor with dimensions according to IEC size 71.

The motor bearing will have to carry a slight axial load from the rotor set. With motors delivered from IMO AB, this load will not significantly impair the bearing life expectancy.

Speed

The maximum speed is 3600 rpm. For higher speeds, contact IMO AB.

Rotation

The pump is designed to operate in one rotational direction only, counter clockwise when facing the shaft end.

For shorter periods of time, a few minutes for emptying a discharge line, the pump may be operated in reverse direction, provided the back pressure is limited to 3 bar.

3. Technical Data

3.3 Sound level

Typical pump sound levels refer to free field conditions at a distance of 1 m from the pump. Noise of driver excluded in the quoted figures. The sound levels are measured at a discharge pressure of 5 bar, 2940 rpm and viscosity 40 cSt, according to ISO-3741.

Size	015	020
Sound level dB [A]	50	52

3.4 Moment of Inertia

Moment of inertia [10^{-6} kgm²]

Size	015	020
Value	5	10

3.5 Fluid viscosity

1,4 – 600 cSt.

For higher viscosity, contact IMO AB.

3.6 Fluid temperature

-20 – +90 °C for all versions of LPD pumps.

4. Design

4.1 Ball bearing

Ball bearing for the pump is not needed since the forces are handled by the ball bearing of the motor.

4.2 Material & design

Model	Material pump	Material rotor	Material idler	Material seal	Material elastomer
LPD	Cast iron	Steel	Cast iron	Carbon/Silicon carbide	Viton

5. Performance Guide

Typical performance values at 5 bar
Flow calculated at 26 cSt, power at 260 cSt.

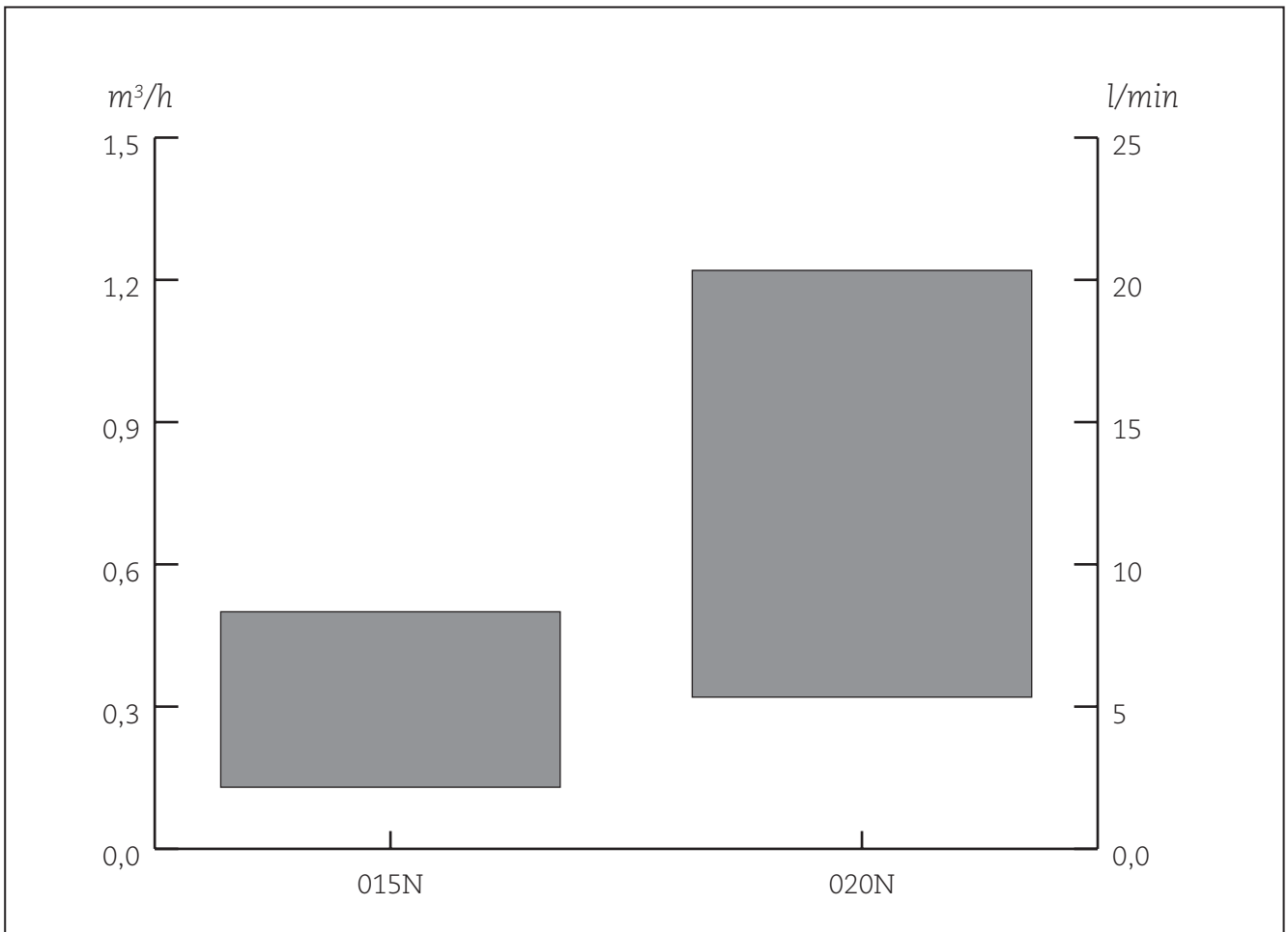

	015N		020N	
rpm	l/min	kW	l/min	kW
1470	2,2	0,1	5,3	0,2
1770	3,1	0,2	7,5	0,3
2950	6,7	0,3	16,0	0,5
3550	8,5	0,4	20,3	0,6

6. Sectional view

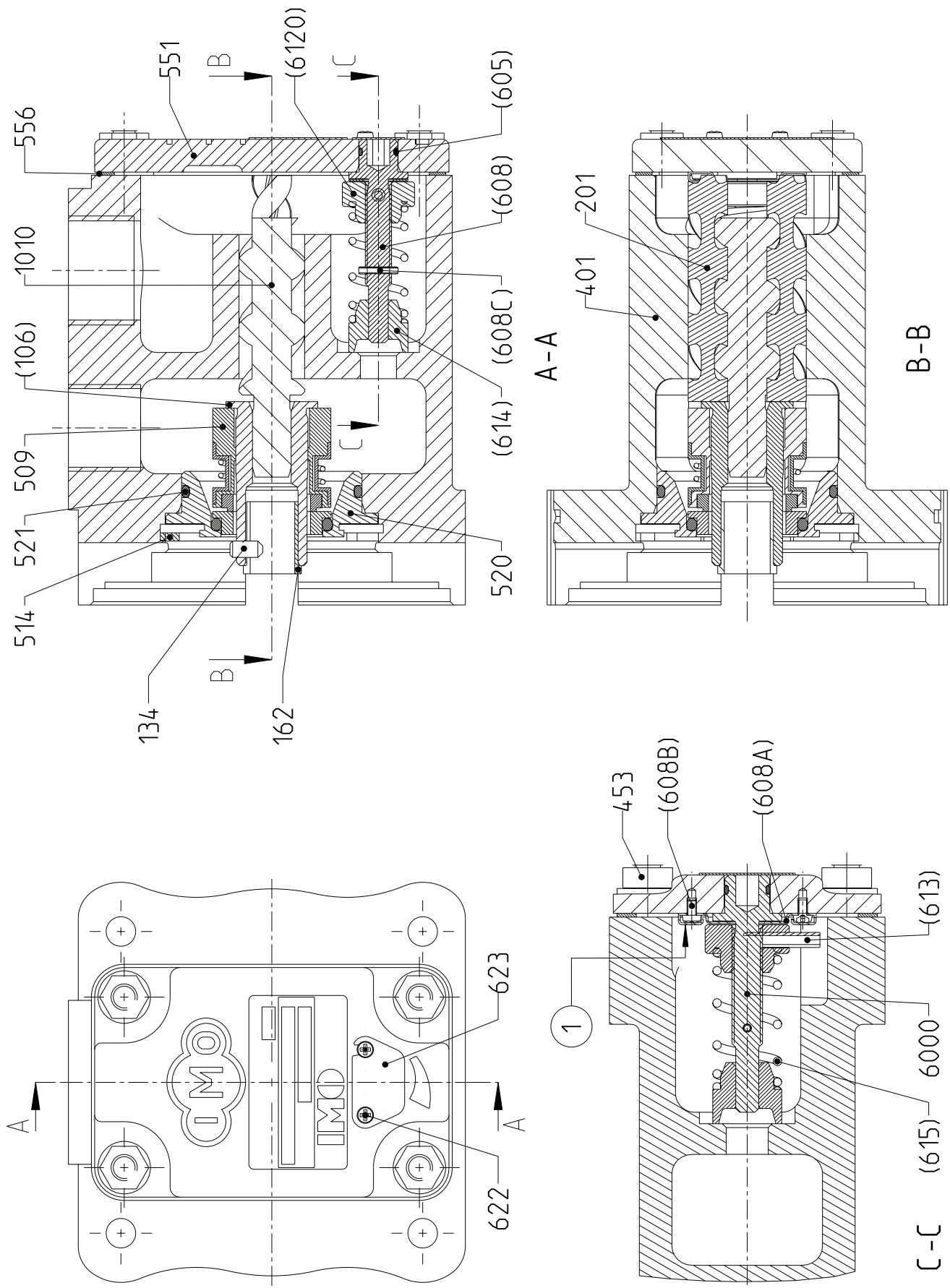

7. List of Components

Pos No	Denomination	Pos No	Denomination
1010	Complete power rotor	6000	Complete valve element
(106)	Shaft	(605)	O-ring
134	Locking screw	(608)	Valve spindle
162	Shaft sleeve	(608A)	Locking clamp
201	Idler rotor	(608B)	Screw
401	Pump body	(608C)	Pin
453	Screw	(6120)	Complete regulating nut
509	Shaft seal	(613)	Tension pin
514	Retaining ring	(614)	Valve piston
520	Front cover	(615)	Valve spring
521	O-ring	622	Screw
551	Rear cover	623	Plate
556	Gasket		

Drawing remarks:

(1) Bend wings of locking clamp(608) over screws(608B)

Notes:

- Components with Pos No within parenthesis are parts of subassembly

8. Pump Dimensions

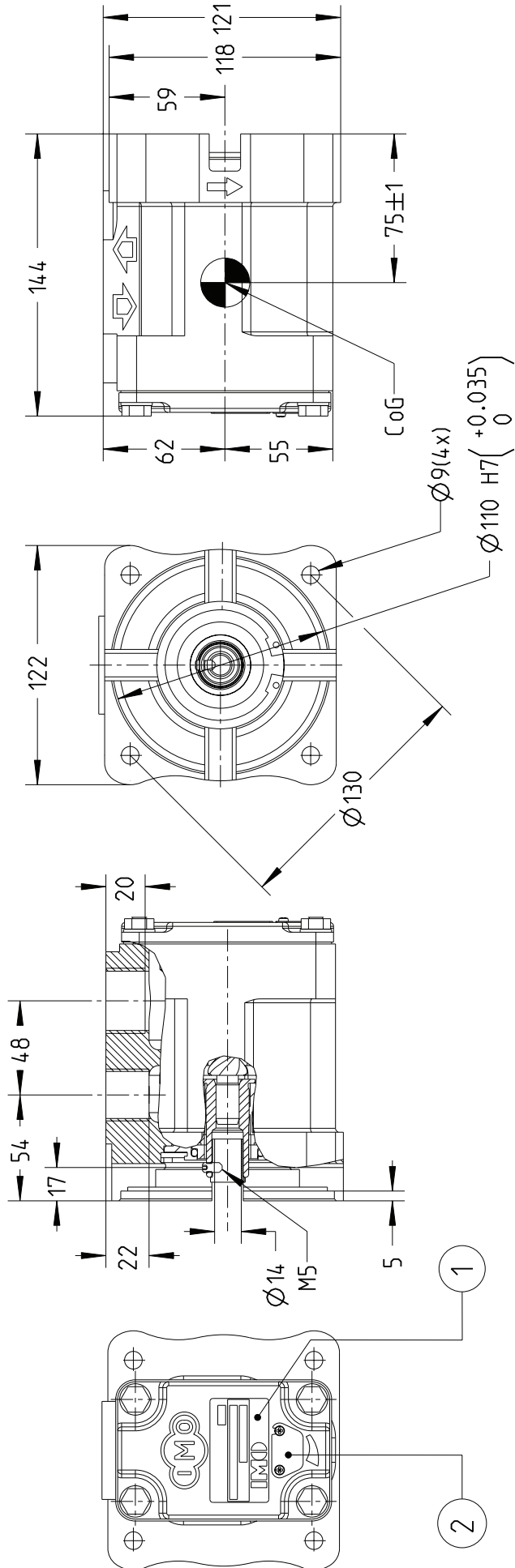

Pump size	Weight kg
015	5.6
020	6.0

8. Pump Dimensions

Drawing remarks:
(1) Name plate
(2) Cover for set screw. Turn set screw clockwise to increase set pressure.
(3) Outlet. ISO G3/4"
(4) Inlet. ISO G1"

Notes:
- Dimensions in mm

9. Pump Unit dimensions

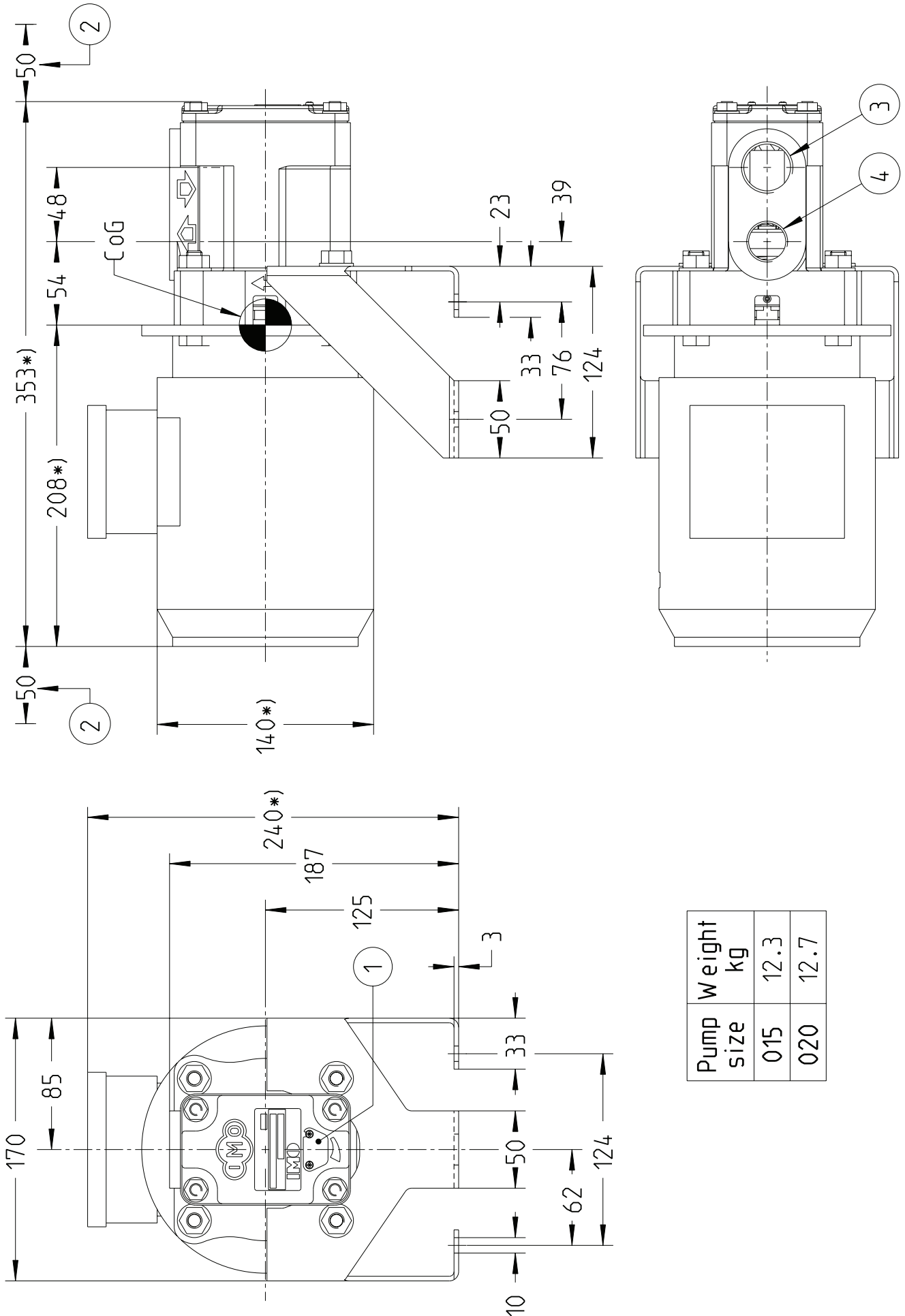

Pump size	Weight kg
015	12.3
020	12.7

9. Pump Unit dimensions

Notes:
- Dimensions in mm

Drawing remarks
(1) Cover for set screw. Turn set screw clockwise to increase set pressure
(2) Space for dismantling
(3) Inlet. ISO G1"
(4) Outlet. ISO G3/4"
*) Dimensions and weight are approximate values for Brook Crompton motors

10. Accessories

A bare shaft pump (Fig. 1) can be ordered with the accessories in fig. 2-3.

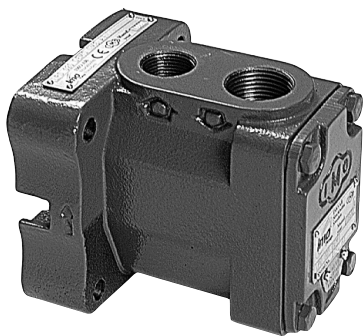

Fig. 1 Bare shaft pump

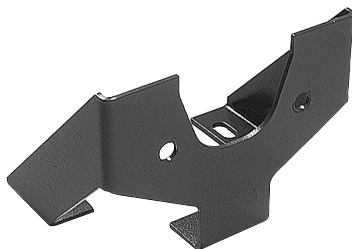

Fig. 2 Connecting frame

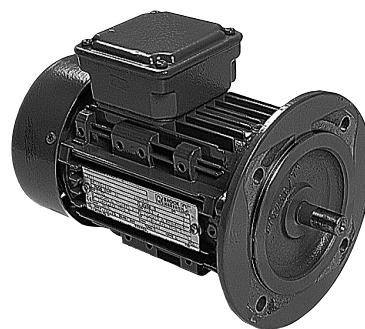

Fig. 3 Electric motor

11. Maintenance and Service

Spare parts for these pumps are easily available from stock. For detailed information and know-how about service, see the Maintenance & Service Instruction for LPD pumps or contact IMO AB.

**For latest updates, check:
www.imo.se**